

## Marine engine

**Objective:** At the end of this lesson you shall be able to

- state the starting system

### Marine engine

Marine automobile engines are types of automobile petrol or diesel engines that have been specifically modified for use in the marine environment. The differences include changes made for the operating in a marine environment, safety, performance, and for regulatory requirements. The act of modifying is called 'marinisation'.

Marine automobile engines are water-cooled; drawing raw water in from a pickup underneath the boat. In an open cooling configuration, the raw water is circulated directly through the engine and exits after passing through jackets around the exhaust manifolds. In a closed cooling configuration anti-freeze circulates through the engine and raw water is pumped into a heat exchanger. In both cases hot water is released into the exhaust system and blown out with the engine exhaust gasses. The transmission oil cooler is also cooled by raw water. (Fig 2)

### Double acting engine (Fig 1)

A double-acting cylinder is a cylinder in which the working fluid acts alternately on both sides of the piston. In order to connect the piston in a double-acting cylinder to an external mechanism, such as a crank shaft, a hole must be provided in one end of the cylinder for the piston rod and this is fitted with a gland or 'stuffing box' to prevent escape of the working fluid. Double-acting cylinders are common in steam engines but unusual in other engine types. Many hydraulic and pneumatic cylinder use them where it is needed to produce a force in both directions. Engine which is fitted to produce a force in both directions. Engine which is fitted with double acting cylinders referred as double acting engine.

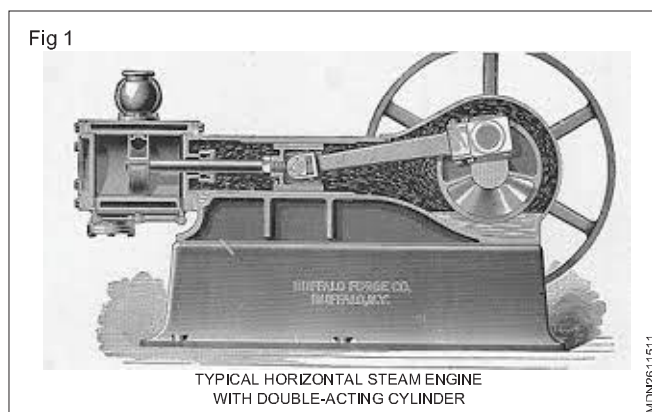
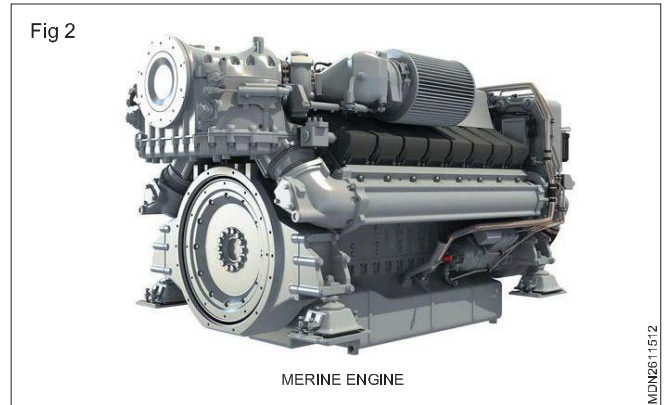

Fig 2



### Opposed piston engine (Fig 3)

Opposed Piston Engine is a type of diesel engine which has two pistons working in the same cylinder. Technically, opposed piston engine is just a variation in the design of conventional engine. Each of the cylinders of the engine has two pistons, one at each end. The main advantage of opposed piston arrangement over others is that they have a higher power to weight ratio.

As mentioned earlier, in an opposed piston engine, there are two pistons at both the ends of the cylinder. The cylinders of opposed piston engine are generally longer in size than those of the conventional engines. The arrangement of cranks is also such that both the pistons move towards and away from each other simultaneously. Moreover, the system works on a two stroke cycle and a uniform method of scavenging. In opposed piston engine the combustion chamber is the space left between the two pistons when both are at inner dead centre positions. It is this place between the pistons where in the fuel injection valve, air starting valve pressure relief valve and indicating cocks are fixed.

Most of the opposed piston engines have two crankshafts, one for the upper piston and other for the lower one. Both the crankshafts are arranged as trunk piston engines and through a series of connected gears. However, the earliest opposed piston engines used to have just one crankshaft in their design. Such arrangement would have three cranks, one at the center which is attached to the lower piston with connecting rod and cross-head. The other two cranks are arranged on the same line as that of the center crank and are connected with the top piston with connecting rods, tie rods and crossheads. The exhaust and scavenge ports at the top and bottom of the cylinder, operates because of the reciprocating motion of the piston. Other equipments such as supercharger, air box etc are attached similar to any conventional diesel engine.

The air fuel mixture is pushed into the space in between the pistons. The ignition of the mixture pushes both the pistons downwards, leading to power stroke. The ignition is usually provided using a spark plug. As both the pistons move downwards, one of the pistons opens the outlet valve, which pushes the gas out of the exhaust, whereas the other piston opens the inlet valve, pushing in the fresh gas mixture. The compression stroke then takes place and the cycle repeats itself.

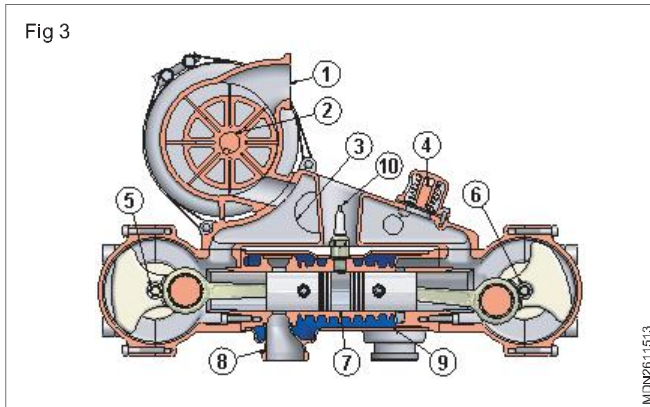

### Advantage - Better Power to Weight Ratio

The main advantage of opposed piston engine is that unlike conventional engines, where the stresses generated due to firing loads are transferred from the cylinders to the bedplates of the engine, no stresses are transferred and thus it has an excellent power to weight ratio. Moreover, the arrangement of opposed piston engines provides a higher degree of balance than the conventional engine.

### Marine & stationary engine starting system

The purpose of the starting system is to provide the torque needed to achieve the necessary minimum cranking speed. As the starter motor starts to rotate the flywheel, the crankshaft is turned and starts piston movement. Small diesel engine; does not need to be a great deal of torque generated by a starter. But marine diesel engine need huge amount of torque to require cranking speed. The most common type of starting system uses electrical energy, compressed air and hydraulic energy.

### Electric starter motor (Fig 4)

An electric starter motor takes stored electrical energy from a battery and converts it into torque at the starter piston gear. The pinion then engages with the flywheel ring gear and the flywheel rotates the engine crankshaft as shown in Fig 4.

### Gear reduction starter motor (Fig 5)

In this starter motor, components like the armature, brushes, brush holder, field coils, pole shoes, and desolders are the same as in a direct drive starter. The armature shaft has a gear output that drives an intermediate gear, which in turn drives another pinion gear.

Electric starting system	Air starting system	Hydraulic starting system
Electric starter motor assembly	Air motor starter assembly	Hydraulic motor starter assembly
Battery cables	Air lines	Hydraulic hoses
Starter relay	Relay valve	Directional control valve
Starter interlock system	Starter interlock system	Starter interlock system
Battery (ies) or capacitor	Air tank	Hydraulic accumulator
Starter switch	Starter switch or valve	Starter switch or valve
Wiring harness	Wiring harness (optional)	Wiring harness (optional)

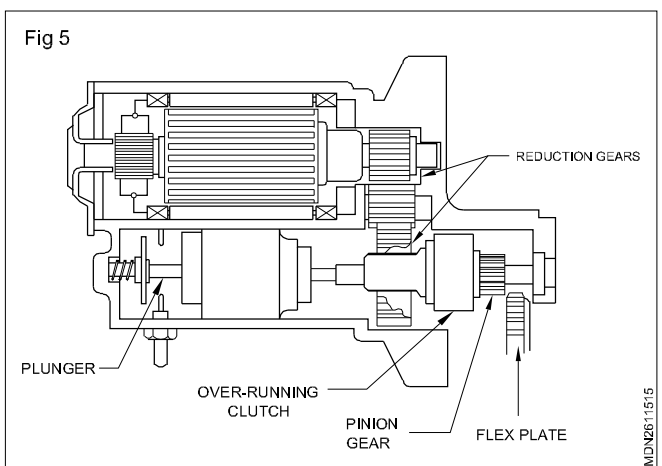
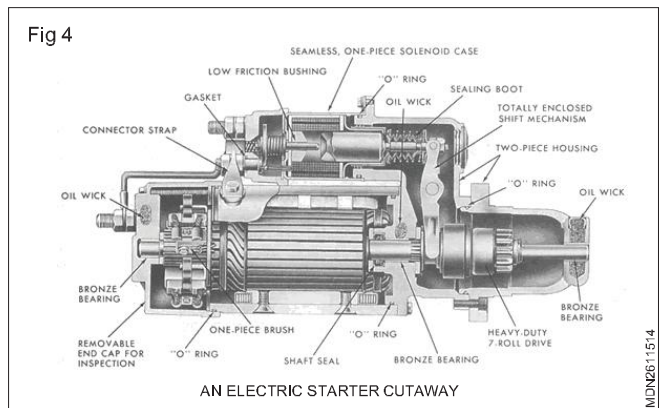

## Air Starting system (Fig 6)

Different engine applications could call for an alternative starting system to the electrical starting system. The environment the machine is working in could be flammable and require a spark-proof machine or the cost of replacing batteries in extremely cold environments is seen to be excessive. One alternative is to use a dedicated air supply to spin an air-powered starter motor assembly.

There are some advantages to having an air driven starter. They are much lighter and, therefore, have a higher power to weight ratio than a comparable output electric starter. There is no chance of an air starter overheating from overcranking. Because of their simple design, there is very little that goes wrong with them. The most problematic area that can cause trouble with an air starter assembly is excessive moisture in the air system that can freeze in cold weather.

One disadvantage is how fast the air supply is depleted when the starter is engaged. Most starting tanks will empty within 20 seconds. If the air tank does deplete before the engine starts, this means charging the tank with an external air source from a shop air line, other machine, or service truck.

An air starter will generate high cranking speed and torque so that under normal conditions the engine should start before the starter air tank runs out.

There are two main types of air starter motors. One is a vane type that uses sliding vanes in a rotor to convert air flow into mechanical movement. The other type is called turbine, and its rotation is created by air flow pushing on the blades of one or more turbine wheels.

If you look back to the chart comparing air, hydraulic, and electrical starting systems, the main differences are the energy supply, type of motor, air lines, and system control.

The machine will most likely have an air compressor to provide air for other pneumatic systems and to keep the starter air tank charged up. Once the engine starts, it is then up to the machine's air compressor to recharge the starting tank and the machine's other supply tanks. The air starting tank will be charged to between 110 and 150 psi.

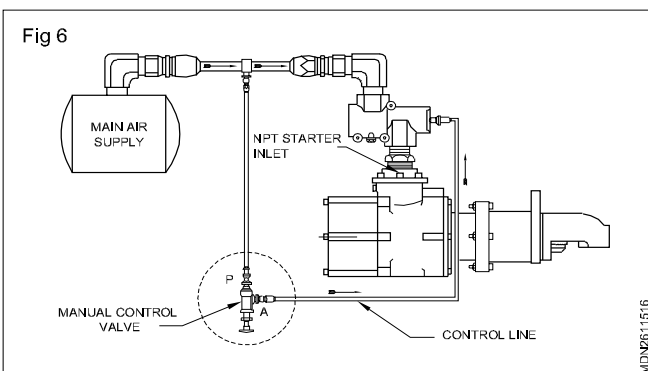

To send air to the starter, a relay valve will be controlled by an electric solenoid valve that is activated by the key switch or there could be a floor-mounted air relay valve to send air to the main relay valve. See Figure to see the arrangement of components for an air starting system. When the solenoid valve is energized, it will send air to the relay valve that will open to allow tank air into the starter motor. There are two main types of starter motors: vane and turbine. The motors create shaft rotation that usually has its speed reduced and torque increased through a gear reduction. The torque is then sent out through a drive pinion to engage with the flywheel. Vane-type motors will need lubrication and will usually have diesel fuel drawn into the motor inlet during starter engagement.

It is important to have clean dry air entering air starters and their control circuit. Problems with moist air are magnified in the winter with relay valves freezing and sticking. Air leaks and air restrictions are the only other concern with air starter systems. The motors will last a long time, and if they are found to be worn out, repair kits can be installed to renew the starter assembly.

## Hydraulic starting system (Fig 7)

Another nonelectric starting system is one that uses hydraulic fluid to rotate a hydraulic starter motor. The motor will then rotate a drive gear in the same manner as typical electric starters. Hydraulic start systems have an accumulator that keep hydraulic fluid stored under pressure until needed. A control valve is actuated to send pressurized fluid to the motor to get the motor turning. The motor is a fixed displacement axial piston unit, and its shaft drives the pinion gear directly. See Figure for a hydraulic starting system. The control valve could be floor mounted, cable operated, or controlled electrically through an LCD screen touch pad called a human-machine interface (HMI).

The accumulator for this system has a pre-charge of 1500 psi of nitrogen, and when the oil is pumped into it, the pressure builds to 3000 psi.

This system will have a backup hand pump that could be used to charge the accumulator.

If the system doesn't operate, then just like an electric or air system, perform a good visual inspection. Then check the accumulator pre-charge pressure and the oil pressure after the accumulator has been charged. If these pressures are good, then look for restrictions or leaks past the accumulator toward the control valve. Make sure that the valve is moving as it should, and if there is still a problem, you may have to install pressure gauges throughout the system to see if there is oil pressure getting past the control valve.

As with any fluid power system, cleanliness is crucial so check for fluid contamination. For information on accumulator service and repair.

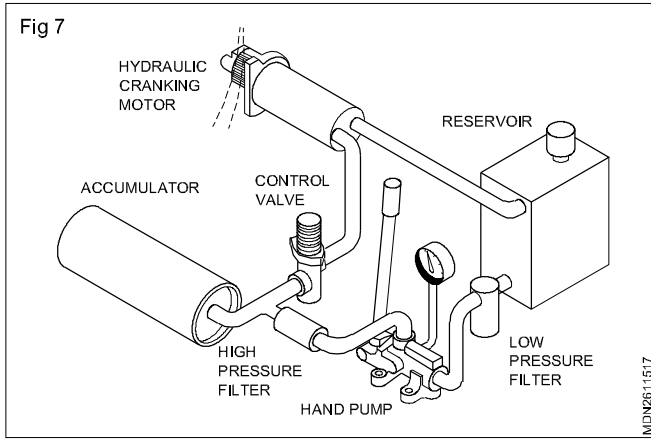

**Air motor starting system for auxilliary engines on ships**

## Auxiliary Engine Automation System

**Objectives:** At the end of this lesson you shall be able to

- Describe the function of auxiliary engine automation system
- Describe the function of auxiliary engine stop system
- Describe the function of marine engine cooling system
- Describe the function of lubricating oil system

The sensors and indicators are installed on engine properly and connected to the power system panel for control and monitoring. The engine responds to the control signals via pneumatic and electronic mechanism of the engine.

The electrical power of DC24V and compressed air of about 30 bar should be supplied consistently during engine operation. The compressed air supplied from the air reservoir is lowered to a proper pressure through reducing valve around starting air motor, which is used for starting and stopping the engine.

The basic functions of the engine automation system are as follows;

- Engine Starting System.
- Engine Stop System.
- Engine Speed control System.
- Engine Safety system

### Auxiliary Engine Starting System (Fig 1)

In air motor starting system, the engine is started by a starting air motor which is operated by compressed air. Figure below shows the compressed air system for starting, stopping and fuel limiting for auxiliary engines on ships.

Refer to the figure above. Compressed air reaches the auxiliary engine at 30 bar pressure. The air pressure is reduced to 6 bar with a reduction valve. A safety valve is also fitted in the line after reducing valve to protect the air starting system components. Air then enters air starting

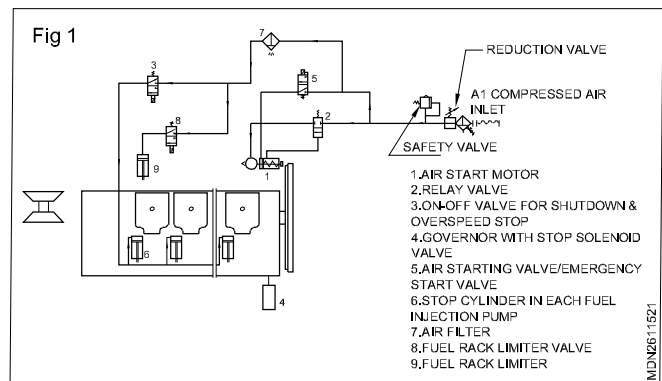

valve (5) and wait there. When 'START' button on the control panel is activated, starting solenoid valve (5) is opened to supply compressed air into the starting air motor (1). Then, the pinion of the air starting motor is engaged with the gear rim of the engine flywheel. As the pinion moves, relay valve (2) is supplied with air and it allows air to the starting air motor turbine wheel. Now air motor turns crankshaft of the engine. When the engine rotating speed reaches predetermined speed, fuel oil is injected into the combustion chamber. Then, starting is completed and the pinion of the air starting motor is disengaged from the gear rim at predetermined speed.

### Purpose of Fuel Rack Limiter

During starting period, the turbocharger is out of normal operation and therefore diesel engine is always in the incomplete combustion due to lack of air, which results in heavy smoke. The fuel rack limiter (9) is used to avoid excessive fuel injected into cylinder during starting period to avoid heavy smoke. During starting period, the engine automation system activate starting solenoid valve to sup-

ply compressed air to push the fuel rack limiter (9) piston. A fuel rack limiter valve (8) supplies air to a pneumatic cylinder or fuel rack limiter (9). The limiting position is set to about 50% load normally. The limiting position can be adjusted by guide when loosening locking screw.

On-off valve (3) is for stopping the engine when engine shut down is necessary or over speed trip is activated. This valve provides air to each stop cylinder (6), connected to each fuel pumps and pulls the rack to cut off fuel to the engine.

### Auxiliary Engine Stop System (Fig 2)

The engine is stopped when pressing 'STOP' button or 'EMERGENCY STOP' button on control panel intentionally, or by 'AUTO STOP' signal. Engine automation system generate 'AUTO STOP' signal when abnormal condition of the engine is detected.

However, the engine is stopped fundamentally when the fuel injection into the combustion chamber is stopped. This means that the rack of each fuel injection pump is moved to stop position by stop signal. Every fuel rack is connected to common control shaft mechanically and also connected to common compressed air line pneumatically.

Therefore, there are two ways of moving fuel racks to stop position (Zero index) as shown in figure below.

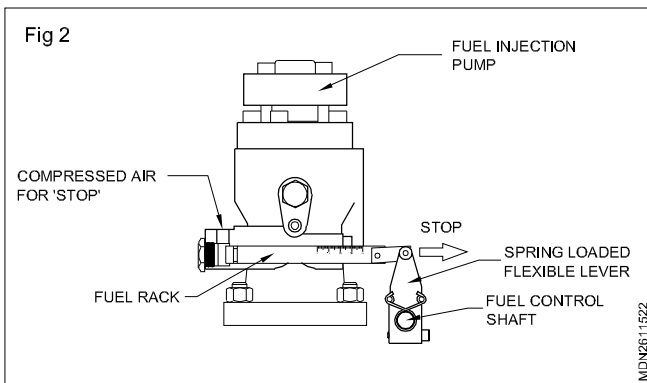

The one is by the mechanical stop, which pull the racks to stop position by the governor or the manual control lever. 'STOP' button activates the governor to be 'STOP' position.

The other is by the pneumatic stop by compressed air (as discussed above with on-off valve 3), which pushes the rack to stop position regardless of the governor control. 'EMERGENCY STOP' button or 'AUTO STOP' signals activates the stop solenoid valve to supply the compressed air for all fuel injection pumps. This 'EMERGENCY STOP' signal also activates governor's stop simultaneously.

However, these two ways are mechanically independent each other and the spring-loaded levers provide mechanical flexibility between them.

### Marine engine cooling system (Fig 3)

There are two types of cooling system used in marine engines.

- 1 Heat exchange cooling system
- 2 Keel cooling system

#### Heat exchange cooling system

Heat exchange cooling system consists of the following units.

Water cooled exhaust manifold.

Engine coolant pump.

Heat exchanger

#### Operation

The coolant flows Fig 3 from the expansion tank (1) around core cells (2). These core cells contain sea water. The water is circulated through the core by the water pump (9). Hot engine coolant flows outside of the core (2) and it is cooled by the sea-water inside the core.

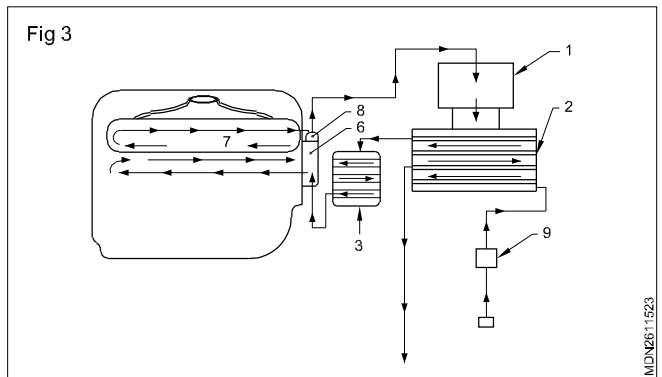

Coolant as fresh water is circulated through an expansion tank (1). From the expansion tank (1) it flows down around the cores (2). From the cores (2) to the oil cooler (3) and then through inlet of engine's coolant pump (6). It is then pumped to the engine and sent to the expansion tank (1) through the exhaust manifold (7) and thermostat (8).

A separate pump (9) is used to circulate sea water to cool cores (2) and back.

#### Keep cooling system

In this system coolant flows from the expansion tank (1) to the keeling coil (2) and goes to the engine (5) through an oil cooler (3). A pump (4) is used to circulate the coolant in system.

#### Open cooling system (Fig 4)

In this system water is stored in a reservoir and circulated in the engine by a water pump. Hot water from the engine is pumped to the reservoir where it flows from a height and gets cooled.

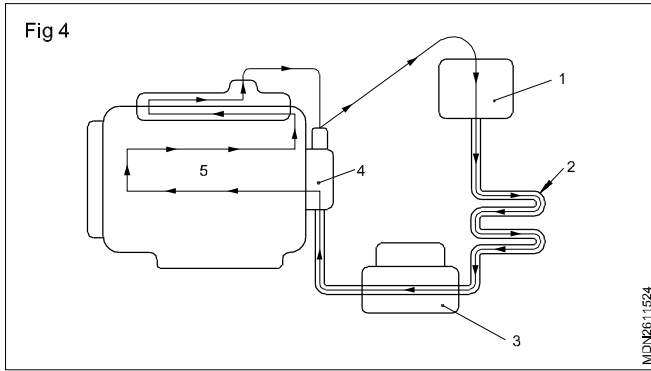

### Marine diesel engine lubrication system

**Function of lubrication:** The lubrication system of an engine provides a supply of lubricating oil to the various moving parts in the engine. Its main function is to enable the formation of a film of oil between the moving parts, which reduces friction and wear. The lubricating oil is also used as a cleaner and in some engines as a coolant.

**Main engine lubricating oil system (Fig 5)** - This system supplies lubricating oil to the engine bearings, and cooling oil to the pistons. Lubricating oil is pumped from main engine lubricating oil. Circulating Tank, placed in the double bottom beneath the engine, by means of the ME LO Pump, to the main engine lubricating oil. Cooler, a thermostatic valve, and through a full-flow filter, to the engine, where it is distributed to the various branch pipes. Pumps and fine filters are arranged in duplicate, with one as a standby. From the engine, the oil collects in the oil pan, from where it is drained to the ME LO Circulating Tank for reuse. A centrifuge is arranged for cleaning the lubricating oil in the system and the clean oil can be provided from a storage tank.

**Lubricating oil system:** Lubricating oil for an engine is stored in the bottom of the crankcase, known as the sump, or in a drain tank located beneath the engine. The oil is drawn from this tank through a strainer, one of a pair of pumps, into one of a pair of fine filters. It is then passed through a cooler before entering the engine and being distributed to the various branch pipes.

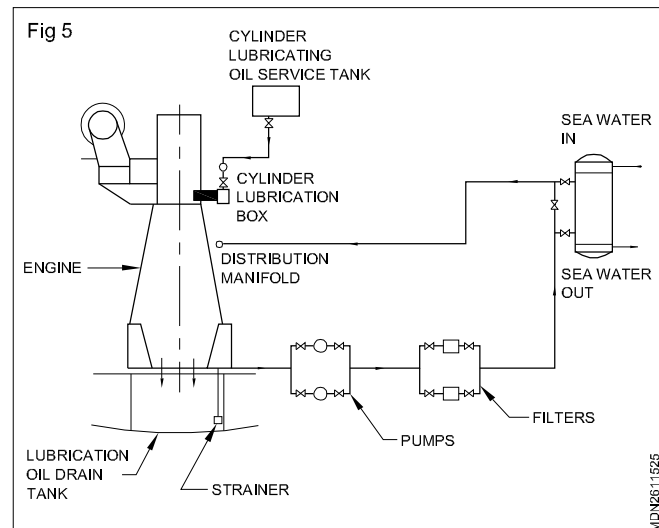

The branch pipe for a particular cylinder may feed the main bearing, for instance. Some of this oil will pass along a drilled passage in the crankshaft to the bottom end bearing and then up a drilled passage in the connecting rod to the gudgeon pin or crosshead bearing.

An alarm at the end of the distribution pipe ensures that adequate pressure is maintained by the pump. Pumps and fine filters are arranged in duplicate with one as standby. The fine filters will be arranged so that one can be cleaned while the other is operating. After use in the engine the lubricating oil drains back to the sump or drain tank for re-use. A level gauge gives a local read-out of the drain tank contents. A centrifuge is arranged for cleaning the lubricating oil in the system and clean oil can be provided from a storage tank.

The oil cooler is circulated by sea water, which is at a lower pressure than the oil. As a result any leak in the cooler will mean a loss of oil and not contamination of the oil by sea water.

Where the engine has oil-cooled pistons they will be supplied from the lubricating oil system, possibly at a higher pressure produced by booster pumps, e.g. Sulzer RTA engine. An appropriate type of lubricating oil must be used for oil-lubricated pistons in order to avoid carbon deposits on the hotter parts of the system.

### Cylinder lubrication

Cylinder oil is pumped from Cylinder Oil Storage Tank to the Cylinder Oil Service Tank, placed min. 3000mm above the cylinder lubricators. The cylinder lubricators are mounted on the roller guide housing, and are interconnected with drive shafts. Each cylinder liner has a number of lubricating orifices, through which the cylinder oil is introduced into the cylinders via non-return valves.

Large slow-speed diesel engines are provided with a separate lubrication system for the cylinder liners. Oil is injected between the liner and the piston by mechanical lubricators which supply their individual cylinder. A special type of oil is used which is not recovered. As well as lubricating, it assists in forming a gas seal and contains additives which clean the cylinder liner.

### Lubricating Oil Sump Level

The level of lubricating oil indicated in the sump when the main engine is running must be sufficient to prevent vortexing and ingress of air which can lead to bearing damage.

The sump level is to be according to manufacturers/ship-builders instructions. The 'Sump Quantity' is always maintained at the same safe operating level and is given in litres. It is essential that the figures are mathematically steady and correct from month-to-month, taking into account consumption, losses and refills and reported.

The 'Sump Quantity' is calculated with the engine stopped, but the lubricating oil pump in operation, thus keeping the system oil in circulation.

Sufficient reserve quantities of lubricating oil must always be held, i.e. to completely fill the main sump and sufficient quantities of other lubes must be held to cover the intended voyage plus 20%. Lubricating oils are a major expenditure item, therefore, all purchasing must be pre-planned with the aim of buying the maximum amounts from the cheapest supply sources which are primarily the US, Europe and Singapore. Lub oil requisitions should be sent to the office at least 10 days before the intended port of purchase and clearly indicate if the vessel requires supply in bulk or in drums.

## Common rail system of marine engines

**Objectives:** At the end of this lesson you shall be able to

- Describe the marine engine CRDI system
- Describe the hydraulic coupling system
- Describe the electromagnetic couplings system
- Describe the reduction gear drive
- Describe the marine electrical drive
- Describe the super charger

The common rail system (Fig 1) is a system which is common for every cylinder or unit of the marine engine. Marine engines of the early times had a fuel system, wherein each unit had its own jerk pump and the oil pressure was supplied through the jerk pumps.

However, in common rail system all the cylinders or units are connected to the rail and the fuel pressure is accumulated in the same. The supplied fuel pressure is thus provided through the rail.

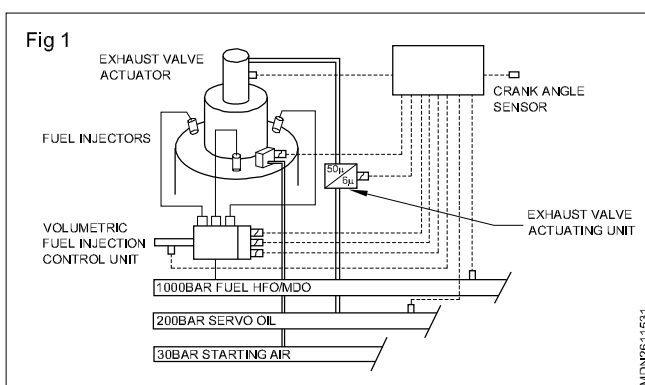

The common rail fuel function system was launched even before the jerk pumps, but was also not successful because of few drawbacks. However, latest advancement in technology and electronics, the common rail system has gained popularity.

The common rail engines are also known as smokeless engines as fuel pressure required for combustion is same for all loads or rpm of the engine.

## Pre-Lubrication Pumps

They provide an essential part of the lubrication system on many types of engine in particular auxiliary engines with engine driven lubricating oil pumps.

They provide a supply of oil to the bearings prior to start up and limit the length of time that boundary lubrication exists, and shorten the time when hydrodynamic lubrication commences. They must be maintained and operated in accordance with the manufacturers' instructions.

The common rail is employed in the following marine engine operating system.

- 1 for heated fuel oil at a pressure of 1000 bars.
- 2 for servo oil for opening and closing of exhaust valves at a pressure of 200 bars.
- 3 control oil for opening and closing of valve blocks at a pressure of 200 bars.
- 4 compressed air for starting main engine.

The common rail system consists of a high pressure pump which can be cam driven or electrical driven or both. Pressure requirement will be different for different system. For fuel oil the pressure are as high as 1000 bars, for servo and control oil the pressure is about 200 bars.

## Valve Block and Electronic control system (Fig 2)

This is required for the control of the flow of the fuel oil, servo oil, control oil and starting air from the rail to the cylinder. The valve block is operated by the electronic control which operates when it gets a signal indicating that this cylinder is at top dead centre (TDC) and fuel has to be injected and decides when exhaust valve has to be opened. With the help of electronics the injection can be controlled remotely from the computer. For e.g. if we want to cut off fuel to one of the unit, then we need to cut off the signal given from the control system so that the valve will not open.

The fuel oil system this block is known as ICU (Injection control Unit) and for exhaust valve it is known as VCU





## Reduction gear drive

Reduction drives are used in engines of all kinds, to increase the amount of torque per revolution of a shaft, the gearbox, differential and steering boxes of any car is an example of a reduction drive.

### Types of reduction gears

There are mainly two type of reduction gears:

- Single reduction gear
- Double reduction gear

#### Single reduction gear (Fig 6)

The arrangement consists of only one one pair of gears. The reduction gear box consists of ports through which the propeller shaft and engine shaft enters the assembly. A small gear known as a pinion is driven by the incoming engine shaft. The pinion directly drives a large gear mounted on the propeller shaft. The speed is adjusted by making the ratio of the speed reduction to the diameter of pinion and gear proportional. Generally, a single gear assembly has a gear double the size of a pinion



#### Double reduction gear (Fig 7)

Double reduction gears are generally used in application involving very high speeds. In this arrangements the pinion is connected to the input shaft using a flexible coupling. The pinion is connected to an intermediate gear know as the first reduction gear. The first reduction gear is then connected to a low speed pinion with the help of one more shaft. This pinion is connected to the second reduction gear mounted directly on the propeller shaft. Such arrangement facilitates the reduction of speed to a ratio as high as 20:1.

#### Reduction drives on marine vessels

Most of the world's ships are powered by diesel engines which can be split into three categories, low speed (<400 rpm), medium speed (400-1200 rpm), and high speed (1200 +rpm). Low speed diesels operate at speeds within the optimum range for propeller usage. Thus it is acceptable to directly transmit power from the engine to the propeller. For medium and high speed diesels, the rota-

tional speed of the crankshaft within the engine must be reduced in order to reach the optimum speed for use by a propeller.

Reduction drives operate by making the engine turn a high speed pinion against a gear, turning the high rotational speed from the engine to lower rotational speed for the propeller. The amount of reduction is based on the number of teeth on each gear. For example, a pinion with 25 teeth, turning a gear with 100 teeth, must turn 4 times in order for the larger gear to turn once. This reduces the speed by a factor of 4 while raising the torque 4 fold. This reduction factor changes depending on the needs and operating

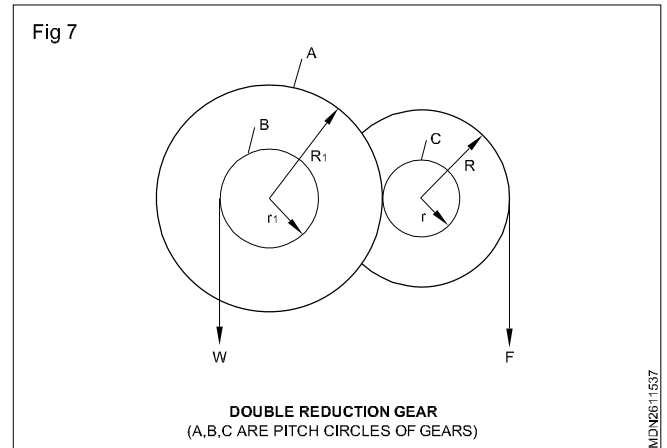

speeds of the machinery. For example the reduction gear ratio of a ship is 3.6714:1.

A large variety of reduction gear arrangements are used in the industry. The three arrangements most commonly used are: double reduction utilizing two pinion nested, double reduction utilizing two-pinion articulated, and double reduction utilizing two-pinion locked train.

The gears used in a ship's reduction gearbox are usually double helical gears. This design helps lower the amount of required maintenance and increase the lifetime of the gears. Helical gears are used because the load upon it is more distributed than in other types. The double helical gear set can also be called a herringbone gear and consists of two oppositely angled sets of teeth. A single set of helical teeth will produce a thrust parallel to the axis of the gear (known as axial thrust) due to created by both sets cancels each other out.

When installing reduction gears on ships the alignment of the gear is critical. Correct alignment helps ensure a uniform distribution of load upon each pinion and gear. When manufactured, the gears are assembled in such a way as to obtain uniform load distribution and tooth contact. After completion of construction and delivery to shipyard it is required that these gears achieve proper alignment when first operated under load.

In order to ensure a reduction drive's smooth working and long lifetime, it is vital to have lubricating oil. A reduction drive that is ran with oil free of impurities like water, dirt, grit and flakes of metal, requires little care in comparison to

other type of engine room machinery. In order to ensure that the lube oil in the reduction gears stay this way a lube oil purifier will be installed with the drive.

### **Marine electrical drive**

Marine motor provides an excellent solution to running marine motor as it provides a low running cost, low maintenance and is almost silent and pollution free.

### **Benefits of electric drive/propulsion**

- The power can be supplied by any number of generator which enables high redundancy.
- The motor drive combination consumes energy only when ship thruster is actively turned.
- The environment benefits from lower fuel consumption and exhaust gas emission levels.
- Electric propulsion is a good platform for the next phase development - hybridization.

Generally ship is designed with modern electric propulsion system as a diesel electric, LNG electric or even fully electric can be quite easily converted a hybrid solution.

### **Generator and motors**

Marine generator operating with diesel engines. The generator power is used for various purposes of the ship etc, lighting propulsion system and communication system. The generator / motor is located between main engine and propulsion shaft, allows the optimum control of propulsion machinery at various speed, which saves energy.

### **Super charger**

Super charging is a process, where a great mass of air is admitted in the cylinder, for combustion and consequently a greater amount of fuel is burnt efficiently. The power output of the engine is increased with higher thermal efficiency without increasing size of engine. The supercharge is driven through gears directly from the engine crankshaft. Supercharging system is commonly used in two stroke and four stroke marine engines, where higher compressed air is needed.