

Electrical power generation by non conventional methods

Objectives: At the end of this lesson you shall be able to

- state the non - conventional energy
- explain the methods of generators power from, bio-gas, micro-hydel, tidal, magnetic hydro dynamic power generation
- list out the merits and demerits of non-conventional power generation.

Non - conventional energy

Energy generated by using wind, tides, solar, geothermal heat and biomass including farm and animal waste is known as non-conventional energy. All these sources are renewable or inexhaustible and do not cause environmental pollution.

Merits of non - conventional over conventional sources of energy

- 1 Provide more energy
- 2 Reduce security risk associated with the use of nuclear energy.
- 3 Reduce pollutants
- 4 Less running and maintenance cost
- 5 Never destroyed
- 6 Despite the high initial investment and several limitations, use of solar energy to meet our ever increasing energy demand seems to be the only answer.
- 7 Green house effect and global warming is avoided
- 8 Less environment problems.

Demerits of non conventional over conventional sources of energy

- 1 Many non-conventional sources are still in their infant stages and required a lot of development efforts. The use of solar energy is a completely a very gentle / minutes operation. Cadmium is used in fabricating thin film solar cells, which is both poisonous and radio active.

But it is very small quantity of cadmium is released from discarded PV panels, Carbondioxide produced while forming silicon from silica increases atmospheric temperature.

- 2 High initial cost
- 3 Less reliable and efficiency
- 4 Can not be used for base load demand.

Bio-gas power generation

The method of generating the electrical energy by using bio-gas is termed as bio-gas power generation.

Bio-gas

Biogas is a good fuel. Bio mass like animal excreta, vegetable wastes and seeds undergo decomposition in the absence of oxygen in a biogas plant and form a mixture of gases. This mixture is the **biogas**. Its main constituent is methane. This is used as a fuel for cooking and lighting.

Aerobic and anaerobic bio- conversion process

There are mainly three aerobic and anaerobic bio conversion process for the biomass energy applications. There are;

Bio products : Converting biomass into chemicals for making products that typically are made from petroleum.

Bio fuels : Converting biomass into liquid fuels for transportation.

Bio power : Burning biomass directly, or converting it into a gaseous fuel or oil, to generate electricity.

Properties of biogas

Main properties of biogas are :

- 1 Comparatively simple and can be produced easily.
- 2 Burns without smoke and does not leave any ash as residues.
- 3 Household wastes and bio-wastes can be disposed off, usefully and in a healthy manner.
- 4 Reduces the use of wood and to a certain extent prevents deforestation.
- 5 The slurry from the biogas plant is excellent manure.

Biogas plant technology & status

The important parts of biogas plant are :

- 1 The tank where biomass undergoes decomposition (digester)
- 2 The tank where biomass is mixed with water (mixing tank)
- 3 The tank where slurry of biomass is collected (out flow tank)
- 4 Arrangement to store gas.

Due to the action of bacteria in the absence of oxygen, biogas is produced in the plant. This is collected in the tank. In the gasholder type plant, the cylinder rises up as the gas fills the tank and the storage capacity increases. The gas storage capacity of dome type will be less than that of gasholder type. Residue of biomass (slurry) can be used as good manure.

Biogas plants are built in several sizes, small (0.5 m³/day) to very large (2500 m³/day). Accordingly, the configurations are simple to complex.

Biogas plants are mainly classified into following two types.

- Continuous type and batch type
- Drum type and dome type

Continuous type

Continuous type biogas plant delivers the biogas continuously and is fed with the biomass regularly. Continuous type biogas plant is of two types.

(A) Single stage continuous type biogas plant

In such a plant phase - I (Acid formation) and phase -II (methanation) are carried out in the same chamber without barrier. Such plants are simple, economical, easy to operate and control. These plants are generally preferred for small and medium size biogas plants. Single stage plants have lesser rate of gas production than the two stage plant.

(B) Two stage continuous type biogas plant

In such a plant phase - I (Acid formation) and phase -II (methane formation) take place in separate chambers. The plant produces more biogas in the given time than the single stage plant. However, the process is complex and the plant is costlier, difficult to operate and maintain. Two stage plant is preferred for larger biogas plant systems.

Batch type biogas plant

The infeed biomass is fed in batches with large time interval between two consecutive batches. One batch of biomass infeed is given sufficient retention time in the digester (30 to 50 days). After completion of the digestion, the residue is emptied and the fresh charge is fed. The fresh biomass charge may be subjected - to aeration or nitrogenation after feeding and then the digester covers are closed for the digestion process. Thereafter, the biogas is derived from the digester after 10 to 15 days. Fermentation continues for 30 to 50 days.

Salient features

- 1 Batch type biogas plant delivers gas intermittently and not continuously.
- 2 Batch type biogas plant may have several digesters (reactors) which are fed in a sequential manner and

discharged in a sequential manner to obtain the output biogas continuously.

- 3 Batch type biogas plants have longer digestion time and are therefore more suitable for materials which are difficult for anaerobic digestion (e.g. harder, fibrous biomass).
- 4 Batch type biogas plant needs initial seeding to start the anaerobic fermentation.
- 5 Batch type biogas plant needs larger volume of the digester to accommodate larger volume of the batch. Hence initial cost is higher.
- 6 Operation and maintenance is relatively more complex. Batch type biomass plants need well organized and planned feeding. Such plants are preferred by European farmers. Such plants are not yet popular in India.

Fixed dome type digester (Fig 1)

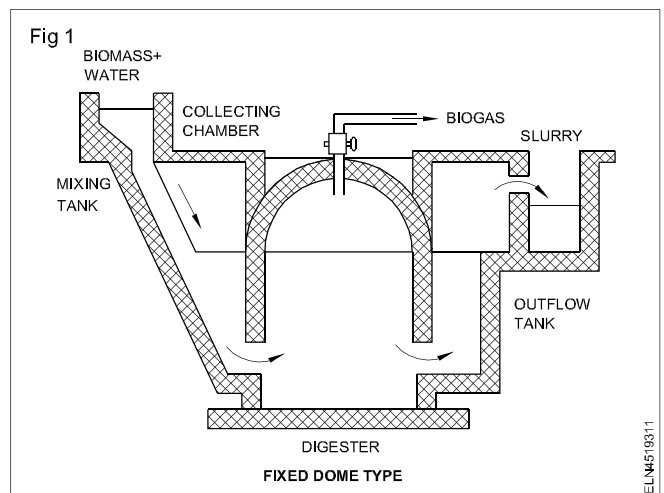

In the fixed dome type digester biogas plant, the digester and gas collector (gas dome) are enclosed in the same chamber. This type of construction is suitable for batch type biogas plant. The digester is conveniently built at or below ground level in comparatively cooler zone. The construction of the digester is with locally available materials like, bricks, terracotta.

The pressure inside the digester increases as the biogas is liberated. The biogas gets collected in the upper portion of the digester in a dome shaped cavity. The outlet pipe is provided at the top of the fixed dome. Alternatively, the gas collector (gas holder) is a separately installed chamber. The digester tank and gas collector chamber are separated by a water seal tank.

The arrangement of a separate gas collector is preferred as the tapping of gas from the gas holder does not affect the pressure and the digestion process in the main digester. The water seal tank prevents the return of the gas from the gas collector to the digester chamber.

An additional displacement chamber may be provided for providing space to the displacement slurry in the digester, due to gas pressure in the upper dome of the fixed type digester. The fixed dome type digester can be fed on daily

basis with small quantities of the slurry. The excess slurry in the digester gets accommodated in the displacement chamber.

The level of the slurry in the main digester and the displacement collector can vary in accordance with the pressure and volume of the biogas in the fixed type of dome. The pressure in the fixed dome and the displacement gas collector are almost the same as they are connected by the outlet from the main digester.

Floating gas holder type (Fig 2)

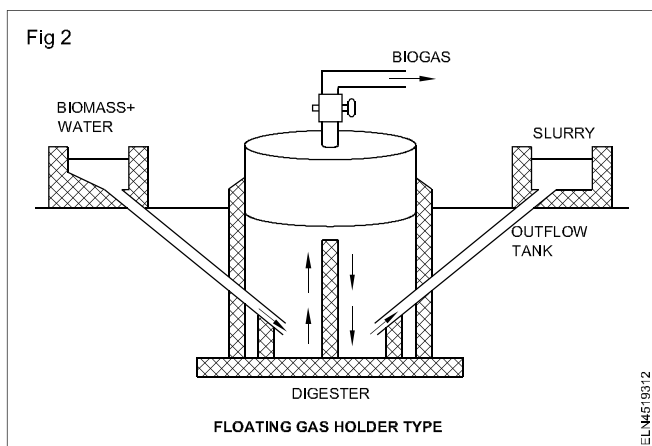

In this design a dome made floats above the slurry in the digester. In the Fig 2 the digester tank is of cylindrical masonry construction. The floating dome is of fabricated steel construction. The dome guide shaft provides the axial guide to the floating dome.

As the gas is collected in it, the sliding bearing provides smooth sliding surface and guide to the floating dome. The gas generated in the slurry gets collected in the dome and the dome rises. The water seal tank provides separation between the gas in the dome and the outlet gas.

Electricity generating plant

Generating plant fuelled by biomass uses conventional steam turbine as used in thermal power stations with modifications to the combustion chamber and fuel handling systems to handle the bulkier fuel. The schematic arrangement is in Fig 3.

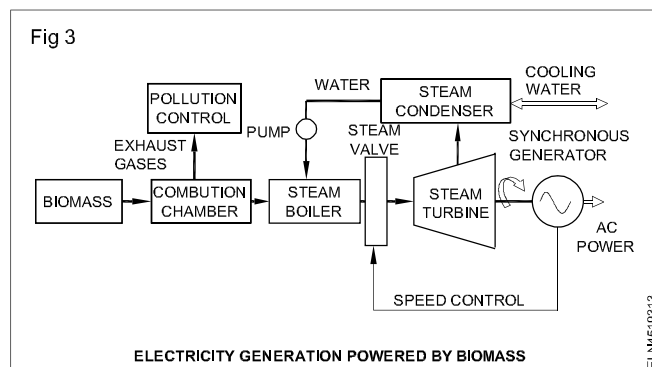

Co - generation

Because of the poor energy conversion efficiencies of biomass fuels, practical generating systems often employ a co-coal generation to achieve reasonable utilization of the generating plant.

Environmental issues

While biomass crops provide an environment friendly fuel source for generating electrical energy. The land used for disposing the slurry (waste) may be better employed for cultivation.

Micro hydel power generation

Micro-Hydel Power (MHP)

The method of generating electrical power by using low head or small flow rate of water is termed as micro hydel power generation.

Small -scale micro hydro power is both an efficient and reliable form of energy, most of time. However, there are certain disadvantages that should be considered before construction a small hydro power system. With the right research and skills, micro hydro can be excellent method of harnessing renewable energy from small streams.

Advantages

a Efficient energy source

It only takes a small flow rate of water (as little as two gallons per minute) or a head as low as two feet to generate the electricity with micro hydro.

b Reliable electricity source

Hydro produces a continuous supply of electrical energy in comparison to other small - scale renewable technologies. The peak energy season is during the winter months when the large quantities of electricity are required.

c No reservoir required

Microhydro is considered to function as a 'run-of-river' system, meaning that the water passing through the generator is directed back into the stream with relatively little impact on the surrounding ecology.

d Cost effective energy solution

Building a small -scale hydro - power system can cost less amount depending on site electricity requirements and location. Maintenance cost are relatively small in comparison to other technologies.

e Power for developing countries

Because of the low-cost versatility micro hydro, the developing countries can adopt and implement the technology to help supply much needed electricity to small communities and villages.

f Integrate with the local power grid

If your site produces a large amount of excess energy, some power companies will buy back your electricity overflow.

g Suitable site characteristic required

In order to take full advantage of the electrical potential of small streams, a suitable site is needed. Factors to consider are; distance from the power source to the location where energy is required, stream size (including flow rate, output and head), inverter, batteries, controller, transmission line and pipelines.

Disadvantages

a Energy expansion not possible

The size and flow of small streams may restrict the future site expansion as the power demand increases.

b Low - power in the summer months

In many locations stream size will fluctuate seasonally. During the summer months there will likely be less flow and therefore less power output. Advanced planning and research will be needed to ensure adequate energy requirements are met.

c Environmental impact

The ecological impact of small - scale hydro should be minimal. Stream water will be diverted away from a portion of the stream, and proper caution must be exercised to ensure there will be no damaging impact on the local ecology or civil infrastructure.

Micro-hydel electric system basic components

Here are some brief descriptions of the common equipment used in grid- intertied and off- grid micro hydro electric systems. The basic components of the systems may vary, where all the following equipment is not necessary for every system.

- Intake
- Pipe line
- Turbine
- Controls
- Dump load
- Battery bank

- Metering
- Main DC disconnect
- Inverter
- AC breaker panel

Intake

Intakes can be as simple as a screened box submerged in the water course, or they can involve a complete damming of the stream. The goal is to divert debris and air-free water into a pipe line. Effectively getting the water into the system's pipe line is a critical issue that often does not get enough attention. Poorly designed intake often become the focus of maintenance and repair effort for hydro-electric systems.

Pipe line

Most hydro turbines require at least a short run of pipe to bring the water to the machine, and some turbines require piping to move water away from it. The length can vary widely depending on the distance between source and the turbine. The pipeline's diameter may range from 1 inch to 1 foot or more, and must be large enough to handle the design flow. Losses due to friction need to be minimized to maximize the energy available for conversion into electricity.

Turbine

The turbine converts the energy in the water into electricity. Many types of turbines are available, so it is important to match the machine to the site's conditions of head and flow.

Controls

The function of a charge controller in a hydro system is equivalent to turning on a load to absorb excess energy. Battery-based micro hydro systems require charge controllers to prevent the overcharging of the batteries. Controllers generally send excess energy to a secondary (dump) load, such as an air or water heater. Unlike a solar - electric controller, a micro hydro system controller does not disconnect the turbine from the batteries. This could create voltages that are higher than some components can withstand, or cause the turbine to over speed, which could result in dangerous and damaging over voltages.

Dump load

A dump load is an electrical resistance heater that must be sized to handle the full generating capacity of the micro hydro turbine. Dump loads can be air or water heaters, and are activated by the charge controller whenever the batteries or the grid cannot accept the energy being produced, to prevent damage to the system. Excess energy is "shunted" to the dump load when necessary.

Battery Bank

By using reversible chemical reactions, a battery bank provides a way to store the surplus energy when more is being produced than consumed. When demand increases beyond what is generated, the batteries can be called on to release the energy to keep your household loads operating.

Metering

System meters measure and display several different aspects of microhydro - electric system's performance and status - tracking the condition of battery, amount of electricity produced and used / consumed.

Main DC disconnect

In battery-based systems, a disconnect between the batteries and inverter is required. This disconnect is a DC-rated breaker mounted in a sheet-metal enclosure. It allows the inverter to be disconnected from the batteries for services and protects the inverter to battery wiring against the electrical faults.

Inverter

Inverter transform the DC electricity stored in battery into AC electricity for powering household appliance. Grid tied inverters synchronize the system's output with the utility's AC electricity, allowing the system to feed hydro

electricity to the utility grid. Battery-based inverters for off-grid or grid-tied systems often include a battery charger, which is capable of charging a battery bank from either the grid or a backup generator.

Micro hydel power working principle

Hydro power is based on simple concepts. Moving water turns a turbine, the turbine spins a generator, and electricity is produced. Many other components may be in a system, but it all begins with the energy already within the moving water.

Water power is the combination of head and flow. Both must be present to produce electricity. Consider a typical hydro system. Water is diverted from a stream into a pipeline, where it is directed downhill and flow through the turbine. The vertical drop (head) creates pressure at the bottom end of the pipeline. The pressurized water drives the turbine. More flow or more head produces more electricity. Electrical power output will always be slightly less than water power input due to the turbine and system efficiencies.

Flow is water quantity, and is expressed as "volume per time". such as gallons per minute (gpm), cubic feet per second (cfs) or litres per minute (lpm). Design flow is the maximum flow for which your hydro system is designed. It will likely be less than the maximum flow of your stream (especially during the rainy season), more than your minimum flow, and a compromise between potential electrical output and system cost.

Tidal power generation

Objectives: At the end of this lesson you shall be able to

- explain the features of tidal power generation
- state the system on which the tidal power generation works
- state the advantages and disadvantages of tidal power generation.

The generation of electricity using tidal power is termed as tidal power generation. It is basically the transformation of tidal power found in tidal motion of water in seas and oceans into electrical energy.

Tidal power

Tidal power is the power inherent in tides at sea or oceans, that is power of motion of water actuated by tides. Tides are defined as the increase and decrease in water levels due to the motion of water from one place to the other. Thus there is a renewable source of energy in the tidal motion of water at seas and oceans. This source of energy could be used to generate other types of energy that could be useful in industrial applications.

This is done using a very basic idea involving the use of a barrage or small dam built at the entrance of a bay where tides are known to reach very high levels of variation. This barrage will trap tidal water behind it creating a difference in water level, which will in turn create potential energy.

This potential energy will then be used in creating kinetic energy as doors in the barrage are opened and the water rush from the high level to the lower level. This kinetic energy will be converted into rotational kinetic energy that will rotate turbines giving electrical energy. Fig 1 shows the process in very simple terms.

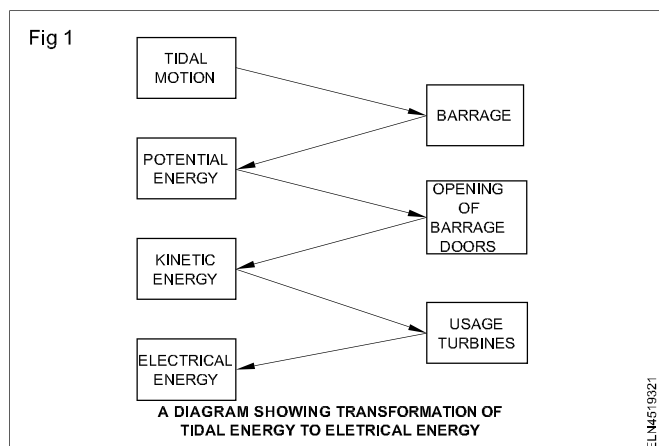

Physical concepts of the tidal phenomena

Tidal movements in seas are due to the increase of water levels at certain areas in the globe and the decrease of water levels at other areas. This is basically due to two factors.

- 1 The gravitational forces between the Sun, Moon and Earth.
- 2 The rotation of the moon and earth.

As there are gravitational forces between the moon and the earth, seas or oceans water is pulled away from earth toward the moon at the area where the moon and the earth are in front of each other. At the opposite side of the earth the water is being pushed away from the earth due to centrifugal forces. Thus there are two areas where the water levels are high and other areas where the water level is low. Thus, the tidal motion of water is created. This is called the **lunar tide**.

Working of tidal power generation system

In very simple terms a barrage is built at the entrance of a gulf and the water levels vary on both sides of the small dam. Passages are made inside the dam and water flows through these passage and turbines rotate due to this flow of water under head of water. Thus, electricity is created using the turbines. A general diagram of the system is in Fig.2.

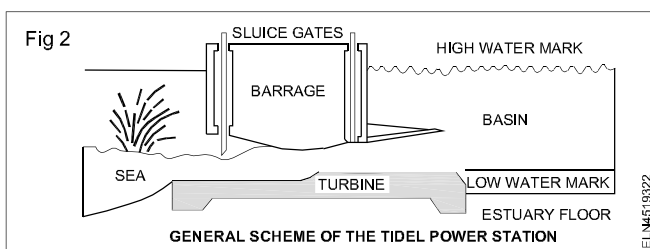

The components of a tidal power station are :

- 1 **A barrage** : a barrage is a small wall built at the entrance of a gulf in order to trap water behind it. It will either trap it by keeping it from going into the gulf when water levels at the sea are high or it will keep water from going into the sea when water level at the sea is low.
- 2 **Turbines** : They are the components responsible for converting potential energy into kinetic energy. They are located in the passage ways that the water flows through when gates of barrage are opened.
- 3 **Sluices** : Sluice gates are the ones responsible for the flow of water through the barrage they could be seen Fig 2.
- 4 **Embankments** : They are caissons made out of concrete to prevent water from flowing at certain parts of the dam and to help maintenance work and electrical wiring to be connected or used to move equipment or cars over it.

The following is a list of different methods of obtaining power from tidal power stations.

1 Ebb method

- 1st - Water starts to ebb or go toward the sea
- 2nd - The gates are left closed keeping the water trapped in basin to increase its level.
- 3rd - Then water is released out toward the sea rotating turbines creating electrical energy.

2 Flood method

- 1st - Water is let into the basin when it is empty
- 2nd - As the turbines are rotated and the electrical energy is created.

3 Ebb plus pumping method

- 1st- The turbines are operated as pumps and pumping the water into the basin at the flood period.
- 2nd - The water level in the basin is increased and creating greater head.
- 3rd - At the ebb phase the water is let out of the basin, creating energy for longer time than usual due to be increased head.

4 Two way power generation

- 1st - Starting with the basin full, the gates are opened, letting water flow out and generating energy.
- 2nd - The turbines are reversed as the flow will be reversed
- 3rd - The gates are closed when the flood period or cycle starts.
- 4th - Water starts to build up behind the dam.
- 5th - When a sufficient head is achieved, the gates are opened to start the flood generation cycle as the water flows into the basin.

5 Two basin generation method

- 1st - Two basins are built one called a high - level basin and the other is the low - level basin .
- 2nd - The turbines are placed in the wall dividing the two basins.
- 3rd - The high level basin is filled at high tide or flood period.
- 4th - Then the low - level basin is filled through the turbines from the high level basin.
- 5th - The low level basin is emptied at low tide ebb period.

Advantages of tidal power generation

There are many advantages of generating power from the tide; some of them are listed below.

- Tidal power is a renewable and sustainable energy resource.
- It reduces dependence upon fossil fuels.
- It produces no liquid or solid pollution.
- It has little visual impact.
- Tidal power exists on a world wide scale from deep ocean waters.
- It offers short time scale between investing in the modular construction and benefiting from the revenue.
- Tidally driven coastal currents provide an energy density four times greater than air, meaning that a 15-m diameter turbine will generate as much energy as a 60m - diameter windmill.
- Tidal currents are both predictable and reliable, a feature which gives them an advantage over both wind and solar systems. Power outputs can be accurately calculated far in advance, allowing for easy integration with existing electricity grids.
- The tidal turbine offers significant environment advantages over wind and solar systems; the majority of the assembly is hidden below the water line and all cabling is along the sea bed.

- Sea water is 832 times as dense as air; therefore the kinetic energy available from a 5-knot ocean current is equivalent to a wind velocity of 270 km/h.

Disadvantages and constraint to tidal power generation

Unfortunately, there are also disadvantages and limitations to generating tidal power. Some of these are;

- At the present time both tide and wave energy are suffering from orientation problems, in the sense that neither method is strictly economical (except in few locations throughout the world) on a large scale in comparison with conventional power sources.
- Tidal power systems do not generate electricity at a steady rate and thus not necessarily at times of peak demand, so unless a way can be found of storing energy efficiently - and any storage devices currently available incur a considerable loss - they would not help in reducing the overall need for fossil power stations, but only allow them to run at a lower rating for a certain amount of the time.
- Tidal fences could present some difficulty to migrating fish.

Magneto hydro dynamic (MHD) power generation

Objectives: At the end of this lesson you shall be able to

- explain the features of magneto hydro dynamic power generation (MHD)
- state and explain the system components of MHD power generation
- state the advantages of MHD power generation.

Magneto hydro dynamic power generation

The way of generating electricity directly from a fast moving stream of ionised gases without the need for any moving mechanical parts - no rotating turbines and generators is termed as magneto hydrodynamic power generation.

MHD power generation has also been studied as a method for extracting electrical power from nuclear reactors and also from more conventional fuel combustion systems.

Working principle

Fig 1 explains the principle of operations of MHD. The MHD generator can be considered to be a fluid dynamo. This is similar to a mechanical dynamo in which the motion of a metal conductor through a magnetic field creates a current in the conductor where as in the MHD generator the metal conductor is replaced by a conducting gas plasma.

The flow (motion) of the conducting plasma through a magnetic field causes a voltage to be generated (and an associated current to flow) across the plasma, perpendicular to both the plasma flow and the magnetic field according to Fleming's Right Hand Rule.

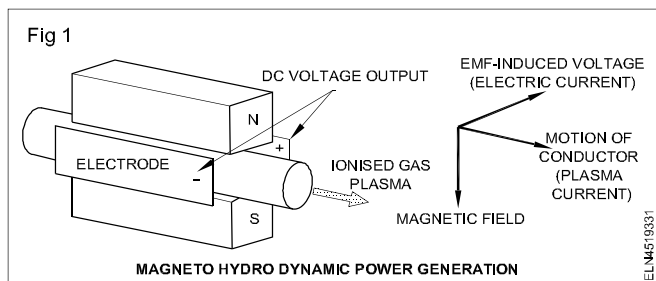

The MHD system

The MHD generator needs a high temperature gas source, which could be the coolant from a nuclear reactor or more likely high temperature combustion gases generated by burning fossil fuels, including coal, in a combustion chamber. The Fig 2 shows the components of this system.

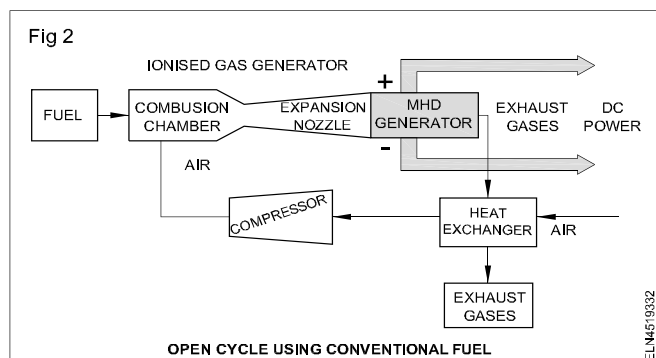

Expansion nozzle

It reduces the gas pressure and consequently increases the plasma speed (Bernoulli's Law) through the generator duct to increase the power output. At the same time, the pressure drop causes the plasma temperature to fall (Gay-Lussac's Law) which also increases the plasma resistance, so a compromise between Bernoulli and Gay-Lussac must be found. The exhaust heat from the working fluid is used to drive a compressor to increase the fuel combustion rate but much of the heat will be wasted unless it can be used in another process.

The plasma

The prime MHD system requirement is creating and managing the conducting gas plasma since the system depends on the plasma having a high electrical conductivity. The plasma can be the fourth state of matter after the solid, liquid and gaseous states, in which the atoms or molecules are stripped of their electrons leaving positively charged ions. Suitable working fluids are gases which derived from combustion, noble gases and alkali metal vapours.

The gas plasma

To achieve high conductivity, the gas must be ionised by detaching the electrons from the atoms or molecules leaving the positively charged plasma. The plasma flows through the magnetic field at high speed, in some designs, more than the speed of sound, the flow of the positively charged particles providing the moving electrical conductor necessary for inducing a current in the external electrical circuit.

Methods of Ionising the gas

Various methods for ionising the gas are available, all of which depend on imparting sufficient energy to the gas. It may be accomplished by heating or radiating the gas with X rays or Gamma rays. It has also been proposed to use the coolant gases such as helium and carbon dioxide employed in some nuclear reactors as the plasma fuel for direct MHD electricity generation rather than extracting the heat energy of the gas through heat exchangers to raise steam to drive turbine generators.

Seed materials such as Potassium carbonate or Cesium are often added in small amounts, typically about 1% of the total mass flow, to increase the ionisation and improve the conductivity, particularly of combustion gas plasmas.

Containment

Since the plasma temperature is typically over 1000°C, the duct containing the plasma must be constructed from non conducting materials capable of withstanding these high temperatures. The electrodes must be conducting as well as heat resistant.

The faraday current

A powerful electromagnet provides the magnetic field through which the plasma flows and perpendicular to this field, two electrodes are installed on opposite sides of the plasma across which the electrical output voltage is generated. The current flowing across the plasma between these electrodes is called the Faraday's current. This provides the main electrical output of the MHD generator.

Power output

The output power is proportional to the cross sectional area and the flow rate of the ionised plasma. The conductive substance is also cooled and slowed in this process. MHD generators typically reduce the temperature of the conductive substance from plasma temperatures to just over 1000°C.

An MHD generator produces a direct current output which needs an expensive high power inverter to convert the output into alternating current for connection to the grid.

Efficiency

Typical efficiencies of MHD generators are around 10 to 20 percent mainly due to the heat lost through the high temperature exhaust.

This limits the MHD's potential applications as a stand alone device but they were originally designed to be used in combination with other energy converters in hybrid applications where the output gases (flames) are used as the energy source to raise steam in a steam turbine plant. Total plant efficiencies of 65% could be possible in such arrangements.

Experience

Demonstration plants with capacities of 50 MW or more have been built in several countries but MHD generators are expensive. Typical use could be in peak shaving applications but they are less efficient than combined - cycle gas turbines which means there are very few installations and MHD is currently not considered for mainstream commercial power generation.

Advantages of MHD generation

- 1 Here only working fluid is circulated, and there are no moving mechanical parts. This reduces the mechanical losses to nil and makes the operation more efficiency.
- 2 The temperature of working fluid is maintained the walls of MHD.
- 3 It has the ability to reach full power level almost directly.
- 4 MHD has very high efficiency
- 5 The price of MHD is very low.

Power generation by solar and wind energy

Objectives: At the end of this lesson you shall be able to

- state the necessity of tapping natural resources for energy
- explain the basic principle and construction of the solar cell
- explain the characteristic and general specification of a solar cell
- explain the features of solar power generation system
- explain the features of wind power generation system
- calculate the required series parallel group of solar cells for a given power requirement.

Solar cells: Heat energy is the most sought energy for human being to cook the food as well as to keep warm in cold climate. However the use of wood as the fuel for fire, has ended up in deforestation and resulted in drought. Search of fuel lead the man to use coal and then oil. However these commodities are fast dwindling and after few hundred years both may completely vanish from earth. As such it is essential that human race should find alternative source of energy from nature.

Hence the use of natural resources like heat from sun thought by several scientists and one of the solutions to the energy crisis is the invention of solar cells.

The solar cells is essentially a large photo diode designed to operate solely as photo voltaic device and to give as much output power as possible. When these cells are under the influence of light rays from sun, they give out about 100 mw/cm² power.

The construction and cross section of a typical power solar cell is in Fig 1. The top surface consist of a extremely thin layer of P-type material through which light can penetrate to the junction.

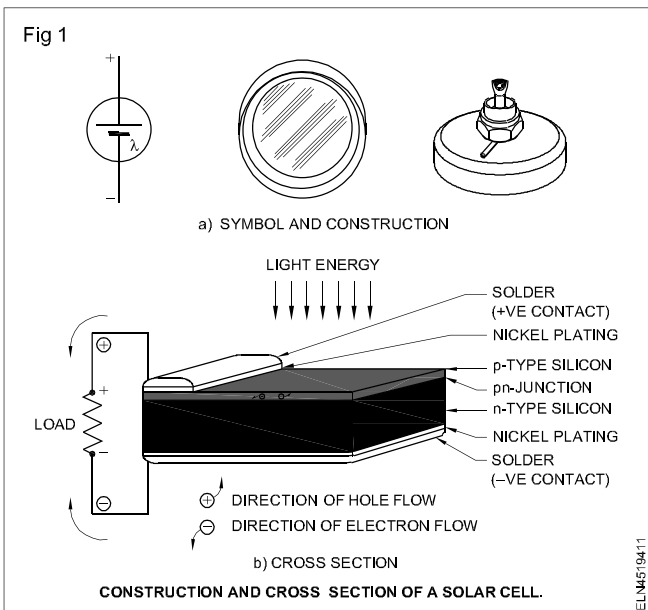

The nickel plated ring around the P-type material is the positive output terminal, and the button plating is the

negative output terminal. commercially produced solar cells will be available in flat strip form for efficient coverage of available surface areas. The circuit symbol of solar cell is shown in Fig 1.

According to different manufacturing standards, the output power varies from 50mw/cm² to 125mw/cm² as shown in Fig 2. The graph (Fig 2) shows the characteristic of a solar cell which gives 100mw/cm². Considering the characteristic curve it is apparent that the cell will deliver an output current of 50mA when the output terminals are short circuited the output voltage will be zero. On the other hand open circuited voltage of the cell will be 0.55mv but the output current is zero. Therefore again the output power is zero. For maximum output power the device must be operated at the knee of the characteristic. In solar cells the output power decreases at high temperature.

Typical output characteristics of power photocell for use as a solar energy converter. (Fig 2)

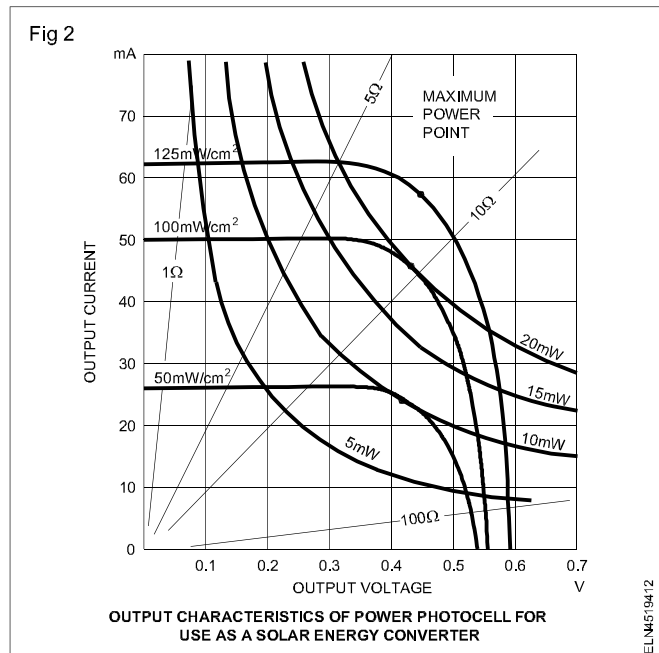

Array of solar cells connected as a battery charger. (Fig 3)

Fig 3 shows a group of series-parallel connected solar cells operating as a battery charger. Several cells must

be series connected to produce the required output voltage, and number of parallel groups to be provided as per the required output current.

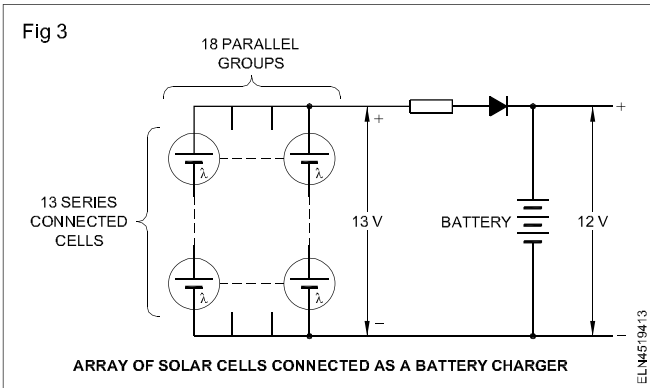

Example

A village welfare club is having a black and white TV which operates at 24V taking a current of 3amp for four hours.

Normally an array of solar cells are used for charging the 24V batteries and the light source from sun available to energise the cells for about 10hours a day. Calculate the total number of solar cells of 125mw/cm² required and the series parallel grouping of cells.

Solution

Refer Fig 2. As per the graph the solar cells (energy converters) should be operated at approximately 0.45V and 57mA. Assuming the charging voltage should be higher than the battery voltage of 24V the solar cells should supply 26.4volt for charging the battery circuit.

Number of series connected cells

$$= \frac{\text{Output voltage}}{\text{Cell voltage}} = \frac{26.4\text{V}}{0.45\text{V}}$$

$$= 58.5 = \text{say } 59 \text{ cells}$$

The charge taken by the batteries after every day of TV programme will be 3amp x 4hours = 12 ampere hours. This should be supplied by the solar cells in 10 hours. Hence the ampere (current) requirement

$$\text{Current} = \frac{\text{Ampere hours}}{\text{hours}} = \frac{12}{10}$$

$$= 1.2 \text{ amp}$$

Total number of groups of cells in parallel

$$= \frac{\text{Output current}}{\text{cell current}} = \frac{1.2\text{amp}}{57\text{mA}}$$

$$= \text{say } 21 \text{ cells}$$

The total number of cells required

$$= \text{Number of cells in series} \times \text{number of groups in parallel}$$

$$= 59 \times 21$$

$$= 1239 \text{ cells.}$$

Solar energy generation

Solar energy is very large, inexhaustible source of energy. The power from the sun intercepted by the earth is approximately 1.8 x 10¹¹ MW, which is many thousands of time large than the present consumption rate on the earth of all commercial energy sources. Thus, in principle, solar energy could supply all the present and future energy needs of the world on a continuous basis. This makes it one of the most promising of the non conventional energy sources.

In addition to its size the solar energy has two other factors in its favour. Firstly, unlike fossil fuels and nuclear power, it is an environmentally clean source of energy. Secondly, it is free and available in adequate quantities in almost all parts of the world where the people live.

However, there are many problems associated with it use. The main problem is that it is a dilute source of energy. Even in the hottest regions of earth, the solar radiation flux available rarely exceeds. 1 KW/m², which is a low value for technological utilization. Consequently, large collecting areas are required in many applications and these result in excessive costs.

Solar electricity

When sunlight strikes on photovoltaic (PV) solar panel, the electricity is produced. The method of generating the electrical energy from the solar panel (cells) is termed as solar energy generation.

Generation of electricity by using solar energy depends up on the photovoltaic effect in some specific materials. There are certain materials that produce electric current when these are exposed to direct sun light. This effect is seen in combination of two thin layers of semiconductor materials. One layer of this combination will have a depleted number of electrons.

When sunlight strikes on this layer, it absorbs the photons of sun light ray and consequently the electrons are excited and jump to the other layer. This phenomenon creates a charge difference between the layer and resulting to a tiny potential difference between them.

The unit of such combination of two layers of semi conductor materials, for producing electric potential difference in sunlight is called solar cell. Silicon is normally used as solar cell. For building cell, silicon material is cut into very thin wafers. Some of these wafers are doped with impurities. Then both doped and undoped wafers are sandwiched together to build solar cell. A metallic strip is attached to two extreme layers to collect current.

A desired number of solar cell are connected together in both parallel and series to form a solar module for producing desired electricity.

The solar cell can also work in cloudy weather as well as is moon light but the rate of production of electricity low as and it depends up on intensity of incident light ray.

Fig 4 describes the typical system of solar panels, controller, energy storage, inverter for converting DC into AC and how the system is connected to power grid.

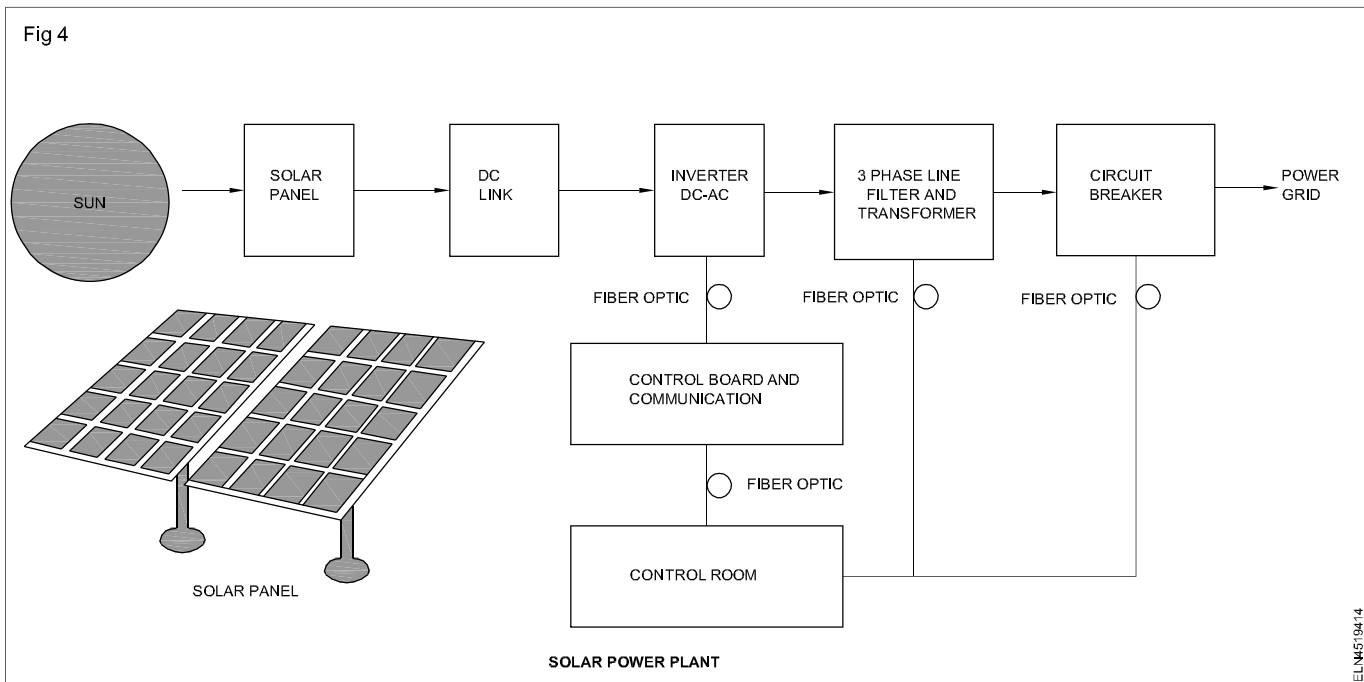

Solar panel installation norms

Solar modules must have some industry standards known as the standard test condition (STC).

It is a set of conditions to test a module, mainly includes these factors.

Irradiance (sunlight intensity)

It is the amount of sunlight falling on a plain surface. Its unit is watt per square metre. The measurement standard is unit $1000\text{Kw}/\text{m}^2$.

Air mass

It is the thickness and clarity of air through which the sunlight passes to reach the modules its standard is 1.5.

Cell temperature : It is the testing temperature as 250°C .

Module efficiency : It is the ratio of output power to the input power is called module efficiency. Module uses the photons in the sunlight to produce DC electricity.

- Normally $1000\text{W}/\text{M}^2$ of sunlight strikes 1 square metre area of a module. If 100W of power is produced from that square metre, then the module efficiency is 10% If it is 50W power is produced from that square metre it has an efficiency of 5%.

- **For efficient cell, it must have the following key factors.**
- It must have a high short circuit current.
- The open circuit voltage is also must be high for obtaining the above possible character with possible condition must be fulfilled.
- By choosing low band gap materials to get high value of short circuit current and high open circuit voltage.

Assembling and installation of solar panels

A solar panel is able to function using the solar energy which is derived from the sun. The solar panel installed on the roof top absorb sun's light (photons) from the sun.

Silicon and the conductors in use for solar panel converts the sunlight into direct current (DC) electricity flows into the inverter. It is a renewable energy. The process of converting sunlight to electrical energy and more efficient than other process.

Solar panel contains many different silicon cells (or) solar cells. The energy derived from the sun is connected into electricity with help of solar panels.

- 1 The solar panels installed on the roof top absorb sun's light from the sun.
- 2 The silicon and the conductor in the panel convert the sunlight into DC flows into inverter.

- 3 The inverter then converts DC to AC which can be used at home.
- 4 Excess electricity that is not used, can be feedback to the grid.
- 5 When the solar panels produce less power than required at home.

Process of connecting solar panel to electricity

Solar panels is used a special process of connecting photons to electrons to generate a current by making use of a special type of cell known as photovoltaic cell. These cells are commonly found on the front of calculation and small gadgets are connected together, called as solar panels (photovoltaic cells) are made up of semiconductor materials such as silicon, which absorb the light from the sun. The photons in the sunlight current the electron within the sunlight.

Basic idea of a solar module, array and balance of system (BOS)

Module

Solar cells are made in various shapes and sizes. The smallest of the cells can be seen in devices like an ordinary calculator, these type of devices are very little amount of power used in home lighting system needs more power to run on. The number of cells are put together to produce more power. The group of cells is packaged together in an enclosed space is called as a **module**.

It helps to give higher voltage, high power and protects the panel from rain, snow and wind etc. voltage and power output of module depend on the size and number of cells used. So, more number of modules are to be connected in a simple assembly of modules is known as **array**. (Fig 5)

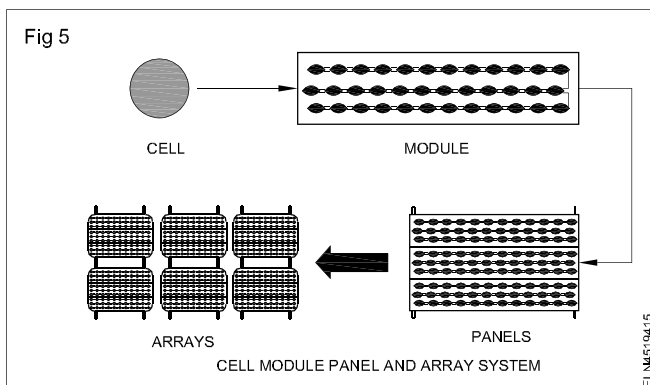

Balance of system (BOS)

The cells modules and arrays are the power producing part, a small devices like radio, needs a small amount of power, can be directly connected to a small module. But most of the devices appliances need more power at night. The assembly of module, battery and an appliance is simple form a P.V system.

A module cannot be connected directly to a battery, so, a charge controller ON charge regulator is used in between module and battery and inverter are required to operate AC appliances. So, the whole system excepts the module is known as balance of system (BOS). (Fig 6)

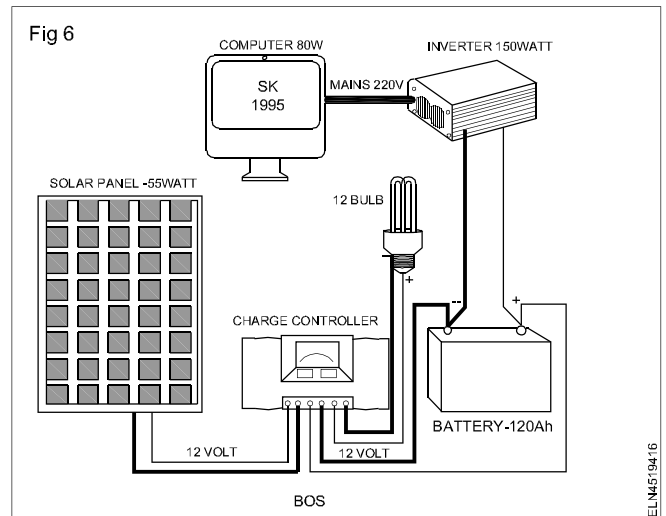

The main components is BOS assembly are:

- Storage battery
- Charge controller
- Inverter
- Support structure
- Junction boxes
- Wire, cables and fuses
- Connections and switches

The functions of the above components are explained briefly below:

Storage battery

The most small systems used for lightening needs only 12V battery for longer system like refrigerator, 24V is used. If helps to keep the wire size small and system losses to a minimum. It needs to be handled carefully. If must not be over charged or fully discharged to prevent from damage.

Charge controller

If the battery is not able to control charge on its own. This work is done by a simple automatic device known as a charge controller in the following way.

- It senses the battery charge and switches 'OFF' the charging current and avoid from damage.
- It disconnects the appliances when the battery charge goes below a set limit.
- Prevents reverse current and protects from short circuit.

Inverter

A solar system produces only DC power. But home appliances need AC power. The device (example CFL) is required for this purpose to convert DC into AC is called as inverter.

Support structure

The solar module cannot be simply placed either on ground or roof. It needs to collect the sunshine at an angle. To keep the module safe from any strong winds support structure is used for solar PV system.

Junction boxes

It is meeting point for many wires. These may be from a row of modules or from modules to a battery bank. A junction box is made of an unbreakable material (ie) polycarbonate. It makes use of copper connectors for a high current flow. It protects the system from moisture.

Wires and fuses

This solar systems carry a low voltage but high current. So, the large diameter wire is needed. Fuses keep the solar equipment safe against the short circuit.

CFL(Compact Fluorescent Lamp)

It is not only energy saving lamp but also having long life (8000hrs) and less heat output common available CFL are:

- 5W - 235 Lumens
- 7W - 370 Lumens
- 9W - 600 Lumens
- 11W - 900 Lumens

The solar panels are installed for some applications like:

- Solar power plant
- Solar lantern
- Solar lighting system
- Solar water pumping system
- Solar battery charging system
- Solar Hybrid system
- Solar grid connected power plants
- Solar home system
- Solar water heater etc.,

For example the procedure for installing of a solar home system is explained below:

Fig 7 shows the block diagram of solar panel installation.

- Collect the system from the packing

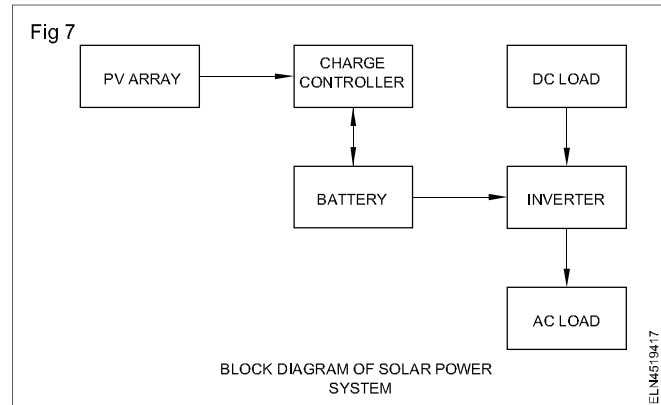

- Check for the any damage from outside on the different parts of system.
- Connect the load to junction box controller
- Connect all lighting loads charge controller to load junction box with interconnecting cables.
- Place the charge controller on batter box, keep the battery inside.
- Fire module on the support structure.
- Wore the system appear box layout.

Mounting of charge controller

- Mount the controller to the wall into screws that fit to the wall material.
- Connect the battery cable assembly with fuse supplied along with the controller.
- Connect first controller and then battery and two modules
- Connect the wires to the load and only then to controller.

Electrical connection

- Connect the battery to the system only after getting fully charged.
- Do not switch 'ON' charged the loads for 2 - 3 days (when battery is 'ON' a full charged)
- Connect the array cable to charge controller with correct polarity.
- Keep the switch in 'OFF' position and connect the load cables and battery cables to charge controller.
- Switch 'ON' the load (ie) lamps for the normal operation.
- Test the solar panel installation for it's functioning.

(Fig 8a & b) shows the installed solar panel with mid clamp and with frame mounted installation are illustrated.

Functionality of solar panel

Sunlight is the basic fuel for a solar panel. Sunshine is the cause to keep the panel for normal functioning. But the environment around the modules will affect it's working.

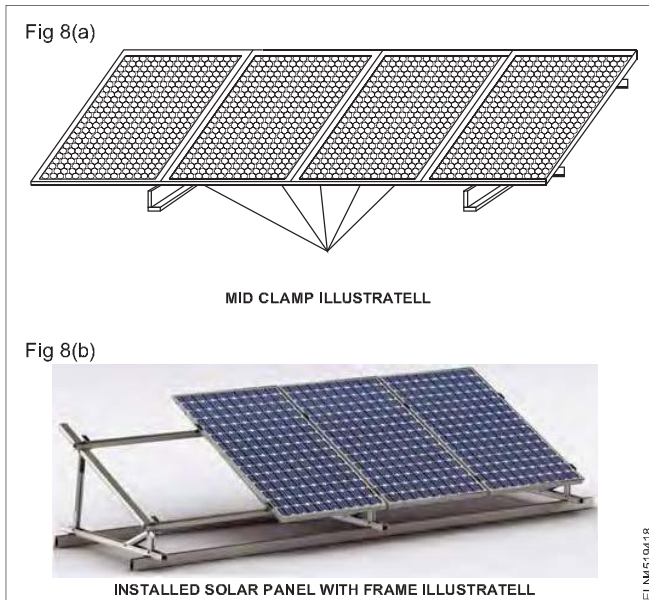

The following few factors will affect its normal working cause for power loss.

- Tilt angle
- Dust
- Shading
- Light intensity
- Temperature
- Charge controller
- Semiconductor energy loss
- Cabling losses
- Improper connections

Tilt angle

The solar module must be installed in the proper path of sun and it is tilted properly at an angle, equal to the latitude of the place. If any error in the tilt angle will lead to same amount of power loss.

Dust

If the modules is not cleaned properly, dust will form on the modules surface in the dry season, and it may cause for high energy loss 5-10%.

Shading

Solar module faces the sun all day. Their shade should

Wind power generation

Objectives: At the end of this lesson you shall be able to

- explain the features of wind power generation
- state the advantages and disadvantages of wind power generation.

The method of generating the electrical energy by using the wind is termed as wind power generation. Since the wind has velocity and kinetic energy, it can be used to

not be present on it. In such a place only it must be put up. But due to extended free transformer, T.V antennas etc, may cause to present shades.

A solar modules are made of a string of individual solar cells and connected in series with one another. Suppose as an example one cell from 36 cells in a module is fully shaded, the power output from the module will become zero due to high resistance. But if one cell is 50% shaded then the power output is reduced to 50% only offers high resistance.

Light intensity

More power is produced from the panel in bright sunlight. For $1000\text{W}/\text{M}^2$ of sunlight, the rated output power will be full. But, if it is $500\text{W}/\text{M}^2$ only the rated power output will be half. The output power is directly proportional with the increasing of solar in isolation.

Temperature

The higher the temperature the output power is reduced from a module, due to power loss. It is tested at standard temperature at 25°C . During the bright sunlight, cell may reach 70°C also. If crystalline silicon decrease from 0.4 to 0.5% per $^\circ\text{C}$ temperature increases above 25°C . Amorphous silicon module temperature coefficient is 0.2 to 0.25 % per $^\circ\text{C}$ of temperature increase.

Charge controller

If the charger controller is in continuous operation and draws a small current of about 5mA to 25mA, then the power loss is around 1%.

Semiconductor energy loss

The charge controller is having the components as MOSFET and blocking diodes, which is cause for heat energy loss.

Cabling loss

The cables are also cause for power loss, It can be minimized by choosing a large diameter of wire size.

Improper connection

If the electrical connections are not made properly, it results in less power is fed to the battery. It can be reduced by keeping clean, and tight connections.

produce electricity. For that, we can use windmills. The important part of a windmill is a structure with large leaves, fixed at the top of a high tower. The speed of leaves

produce electricity. For that, we can use windmills. The important part of a windmill is a structure with large leaves, fixed at the top of a high tower. The speed of leaves

changes with the speed of the wind. If the rotation of the windmill is given to the rotor of a generator, then the electricity will be obtained from the generator. If the windmill is connected to a water pump, the leaves of the windmill rotate the pump and pumping out the water.

Wind power can be usefully exploited for the generation of electricity as there are large, coastal, hill and desert areas. Wind turbines comprising of machines with blade diameter of 17 m, which can generate about 100 kilowatts. A strike of blowing wind on specially designed blades of a windmill's rotor causes both to rotate. This rotation, which is the mechanical energy, when coupled to a turbine, drive the power generator.

Operation

The schematic arrangement of wind power station is given in Fig 1.

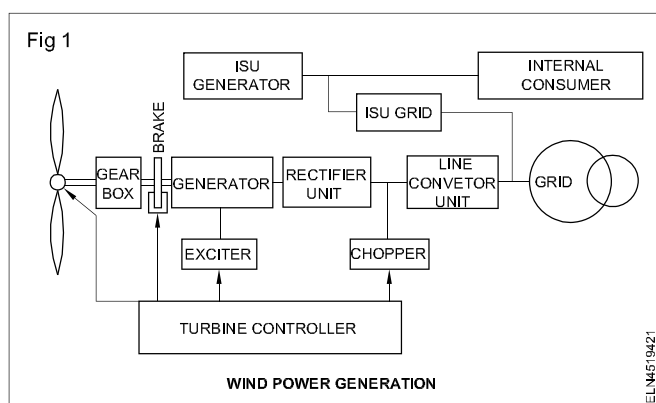

When the wind strikes the rotor blades, blades start rotating. Rotor is directly connected to high speed gear box. Gear box converts the rotor rotation into high speed which rotates the electrical generator. An exciter is needed to give the required excitation to the coil so that it can generate required voltage. The exciter current is controlled by a turbine controller which senses the wind speed based on that it calculate the power what we can achieve at that particular wind speed.

The output voltage of electrical generator is given to a rectifier and rectifier output is given to line converter unit to stabilise the output AC that is fed to the grid by a high voltage transformer. An extra units is used to give the power to internal auxiliaries of wind turbine (like motor, battery etc), this is called **internal supply unit**. ISU can take the power from grid as well as from wind. Chopper is used to dissipate extra energy from the Rectifier Unit (RU) for safety purpose.

Advantages

- 1 The wind energy is free, inexhaustible and does not need transportation.
- 2 Wind power plant on the other hand does not take long time to construct. Such wind mills will be highly desirable & economical to the rural areas which are far away from the existing grids.

- 3 There is a strong reason why wind power should be welcome by grids which have some hydroelectricity inputs in India. The water level in the hydel reservoir is at its lowest before the onset of the South West monsoon. If less water is drawn during the monsoon, a high level could be maintained for longer period. During the monsoon period wind energy can be used to feed the grid.
- 4 It is non polluting
- 5 It does not require high technology.
- 6 Electricity can be produced at a lower cost after installation.

Disadvantages

- 1 The major disadvantage associated in the wind power is that it is not constant and steady, which make the complications in designing the whole plant.
- 2 The rotor blades of wind turbine generators must sweep out large areas to produce worthwhile amount of power.
- 3 The wind is a very dangerous such storms can cause tremendous shear stresses which may spoil the whole plant within no time. To avoid this, special and costly designs and controls are always required.
- 4 Among all the disadvantages mentioned above, the cost factor is the major which has restricted the development of wind power on large scale for feeding to the existing grid. The estimated cost of wind electricity generation, storage & distribution system is over 1 lakh rupees which may be considered beyond the means of most Indian villages.

Modern wind machines are still wrestling with the problem of what to do when the wind is not blowing. Large turbines are connected to the utility power network some other type of generator picks up the load when there is no wind. Small turbines are often connected to diesel/electric generators or sometimes have a battery to store the extra energy they collect when the wind is blowing hard.

The wind energy is utilized by means of a wind mill or a series of wind mills. A wind mill consists of few vanes (normally 3 to 6) which rotate about their axis, when the wind blows against them. The rotational motion (i.e. mechanical energy) thus created is utilized for various applications, such as,

- 1 Lifting water from the well
- 2 Battery charging
- 3 Water pumping
- 4 Operating a simple machine
- 5 Wind energy is used for agricultural & rural applications such as grinding flour mills, wood cutting saw, stone crushers, mixers, water pumps and irrigation facility etc.