

Types of metals

The metals is of two types:

- 1 Ferrous metal
- 2 Non-ferrous metal

1 Ferrous metals : The metals that contains major part of iron and contain carbon sre called ferrous metals such as pig iron, mild steel, nickel etc., they have iron properties such as rusting, magnetisations etc.

2 Non-ferrous metals : The metals that do not contains iron or carbon and do not have the property of iron are called non-ferrous metals such as copper, aluminum etc.

Ferrous and Non ferrous alloys

Alloying metals and ferrous alloys

An alloy is formed by mixing two or more metals together by melting.

For ferrous metals and alloys, iron is the main constituent metal. Depending on the type and percentage of the alloying metal added, the property of the alloy steel will vary.

Metals commonly used for making alloy steels

Nickel (Ni)

This is a hard metal and is resistant to many types of corrosion rust.

It is used in industrial applications like nickel, cadmium batteries, boiler tubes, valves of internal combustion engines), engine spark plugs etc. The melting point of nickel is 1450°C. Nickel can be magnetised. In the manufacture of permanent magnets a special nickel steel alloy is used. Nickel is also used for electroplating. Invar steel contains about 36% nickel. It is tough and corrosion resistant. Precision instruments are made of Invar steel because it has the least coefficient of expansion.

Nickel-steel alloys are available containing nickel from 2% to 50%.

Chromium (Cr)

Chromium, when added to steel, improves the corrosion resistance, toughness and hardenability of steel. Chromium steels are available which may contain chromium up to 30%.

Chromium, nickel, tungsten and molybdenum are alloyed for making automobile components and cutting tools.

Chromium is also used for electroplating components. Cylinder liners are chrome-plated inside so as to have wear resistance properties. Stainless steel contains about 13% chromium. Chromium-nickel steel is used for bearings. Chrome-vanadium steel is used for making hand tools like spanners and wrenches.

Manganese (Mn)

Addition of manganese to steel increases hardness and strength but decreases the cooling rate.

Manganese steel can be used to harden the outer surface for providing a wear resisting surface with a tough core. Manganese steel containing about 14% manganese is used for making agricultural equipment like ploughs and blades.

Silicon (Si)

Addition of silicon for alloying with steel improves resistance to high temperature oxidation.

This also improves elasticity, and resistance against corrosion. Silicon alloyed steels are used in manufacturing springs and certain types of steel, due to its resistance to corrosion. Cast iron contains silicon about 2.5%. It helps in the formation of free graphite which promotes the machineability of cast iron.

Tungsten (W)

The melting temperature of tungsten is 3380° C. This can be drawn into thin wires.

Due to this reason it is used to make filaments of electric lamps.

Tungsten is used as an alloying metal for the production of high speed cutting tools. High speed steel is an alloy of 18% tungsten, 4% chromium and 1% vanadium.

Stellite is an alloy of 30% chromium, 20% tungsten, 1 to 4% carbon and the balance cobalt.

Vanadium (Va)

This improves the toughness of steel. Vanadium steel is used in the manufacture of gears, tools etc. Vanadium helps in providing a fine grain structure in tool steels.

Chrome-vanadium steel contains 0.5% to 1.5% chromium, 0.15% to 0.3% vanadium, 0.13% to 1.10% carbon.

This alloy has high tensile strength, elastic limit and ductility. It is used in the manufacture of springs, gears, shafts and drop forged components.

Vanadium high speed steel contains 0.70% carbon and about 10% vanadium. This is considered as a superior high speed steel.

Cobalt (Co)

The melting point of cobalt is 1495°C. This can retain magnetic properties and wear- resistance at very high temperatures. Cobalt is used in the manufacture of magnets, ball bearings, cutting tools etc. Cobalt high speed steel (sometimes known as super H.S.S.) contains about 5 to 8% cobalt. This has better hardness and wear resistance properties than the 18% tungsten H.S.S.

Molybdenum (Mo)

The melting point of molybdenum is 2620°C. This gives high resistance against softening when heated. Molybdenum high speed steel contains 6% of molybdenum, 6% tungsten, 4% chromium and 2% vanadium. This high speed steel is very tough and has good cutting ability.

Cadmium (cd)

The melting point of cadmium is 320°C. This is used for coating steel components.

Alloying Metals and Non Ferrous Alloys

Non-ferrous Metals And Alloys

Copper and its alloys

Metals without iron are called non-ferrous metals. Eg. Copper, Aluminium, Zinc, Lead and Tin.

Copper

This is extracted from its ores 'MALACHITE' which contains about 55% copper and 'PYRITES' which contains about 32% copper.

Properties

Reddish in colour. Copper is easily distinguishable because of its colour.

The structure when fractured is granular, but when forged or rolled it is fibrous.

It is very malleable and ductile and can be made into sheets or wires.

It is a good conductor of electricity. Copper is extensively used as electrical cables and parts of electrical apparatus which conduct electric current.

Copper is a good conductor of heat and also highly resistant to corrosion. For this reason it is used for boiler fire boxes, water heating apparatus, water pipes and vessels in brewery and chemical plants. Also used for making soldering iron.

The melting temperature of copper is 1083°C.

The tensile strength of copper can be increased by hammering or rolling.

Copper Alloys

Brass

It is an alloy of copper and zinc. For certain types of brass small quantities of tin or lead are added. The colour of brass depends on the percentage of the alloying elements. The colour is yellow or light yellow, or nearly white. It can be easily machined. Brass is also corrosion-resistant.

Brass is widely used for making motor car radiator core and water taps etc. It is also used in gas welding for hard soldering/brazing. The melting point of brass ranges from 880 to 930°C.

Brasses of different composition are made for various applications.

Bronze

Bronze is basically an alloy of copper and tin. Sometimes zinc is also added for achieving certain special properties. Its colour ranges from red to yellow. The melting point of bronze is about 1005°C. It is harder than brass. It can be easily machined with sharp tools. The chip produced is granular. Special bronze alloys are used as brazing rods.

Bronze of different compositions are available for various applications.

Lead and its alloys

Lead is a very commonly used non-ferrous metal and has a variety of industrial applications.

Lead is produced from its ore 'GALENA'. Lead is a heavy metal that is silvery in colour when molten. It is soft and malleable and has good resistance to corrosion. It is a good insulator against nuclear radiation. Lead is resistant to many acids like sulphuric acid and hydrochloric acid.

It is used in car batteries, in the preparation of solders etc. It is also used in the preparation of paints.

Lead Alloys

Babbit metal

Babbit metal is an alloy of lead, tin, copper and antimony. It is a soft, anti-friction alloy, often used as bearings.

An alloy of lead and tin is used as 'soft solder'.

Zinc and its alloys

Zinc is a commonly used metal for coating on steel to prevent corrosion. Examples are steel buckets, galvanized roofing sheets, etc.

Zinc is obtained from the ore-calamine or blende.

Its melting point is 420°C.

It is brittle and softens on heating; it is also corrosion-resistant. Due to this reason it is used for battery containers and is coated on roofing sheets etc.

Galvanized iron sheets are coated with zinc.

Tin and tin alloys

Tin

Tin is produced from cassiterite or tinstone. It is silvery white in appearance, and the melting point is 231°C. It is soft and highly corrosion-resistant.

It is mainly used as a coating on steel sheets for the production of food containers. It is also used with other metals, to form alloys.

Example: Tin with copper to form bronze. Tin with lead to form solder. Tin with copper, lead and antimony to form Babbit metal.

Aluminium

Aluminium is a non-ferrous metal which is extracted from 'BAUXITE'. Aluminium is white or whitish grey in colour. It has a melting point of 660°C. Aluminium has high electrical and thermal conductivity. It is soft and ductile, and has low tensile strength. Aluminium is very widely used in aircraft industry and fabrication work because of its lightness. Its application in the electrical industry is also on the increase. It is also very much in use in household heating appliances.

Metal:

Metal is a mineral used in all types of engineering works such as machineries, bridges, aero planes etc., so we must have basic knowledge about the metals.

Understanding the physical and mechanical properties of metals has become increasingly important for a machinist since he has to make various components to meet the designed service requirements against factors, such as the raise of temperature, tensile, compressive and impact loads etc. A knowledge of different properties of materials will help him to do his job successfully. If proper material/metal is not used it may cause fracture or other forms of failures, and endanger the life of the component when it is put into function.

Fig 1 shows the way in which the metals get deformed when acted upon by the same load.

Note the difference in the amount of deformation.

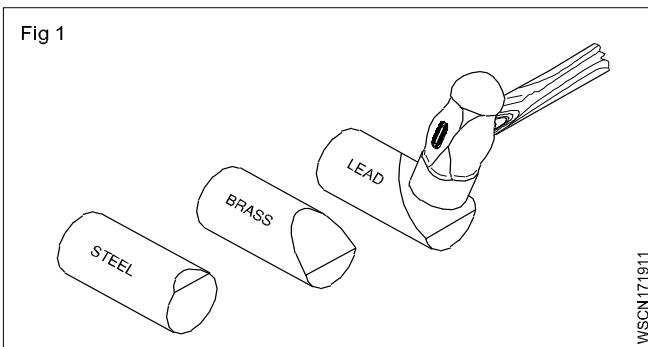

Physical properties of metals

- Colour
- Weight/specific gravity
- Structure
- Conductivity
- Magnetic property
- Fusibility

Colour

Different metals have different colours. For example, copper is distinctive red colour. Mild steel is blue/black sheen.

Weight

Metals may be distinguished, based on their weights for given volume. Metals like aluminium lighter weight (Specific gravity 2.7) and metals like lead have a higher weight. (Specific gravity 11.34)

Structure (Figs 2 and 3)

Generally metals can also be differentiated by their internal structures while seeing the cross-section of the bar through a microscope. Metals like wrought iron and aluminium have a fibrous structure and metals like cast iron and bronze have a granular structure.

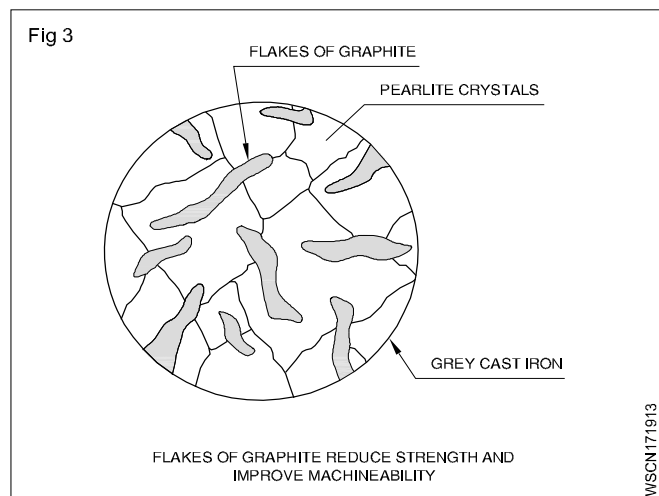
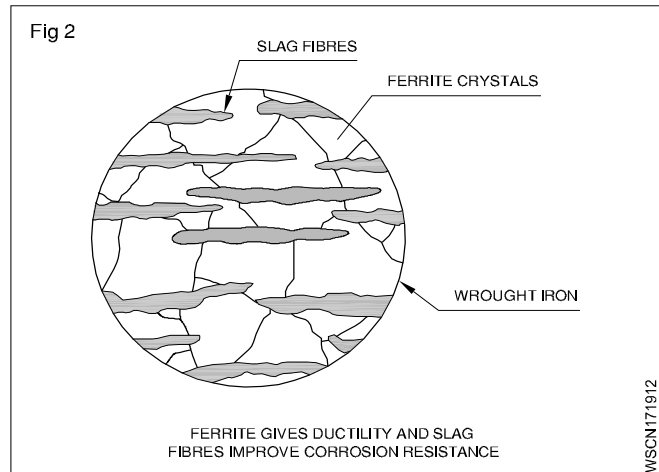

Conductivity (Figs 4 and 5)

Thermal conductivity and electrical conductivity are the measures of ability of a material to conduct heat and electricity. Conductivity will vary from metal to metal. Copper and aluminium are good conductors of heat and electricity.

Magnetic property

A metal is said to possess a magnetic property if it is attracted by a magnet.

Almost all ferrous metals, except some types of stainless steel, can be attracted by a magnet, and all non-ferrous metals and their alloys are not attracted by a magnet.

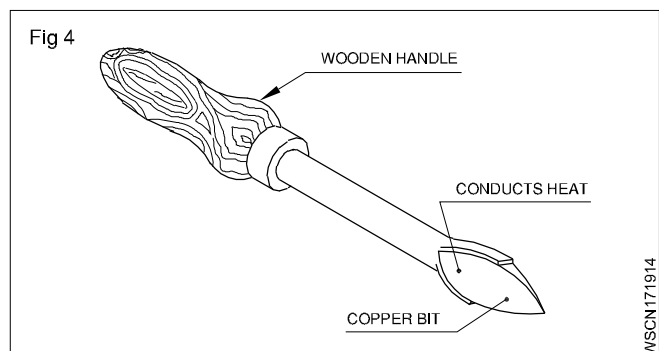

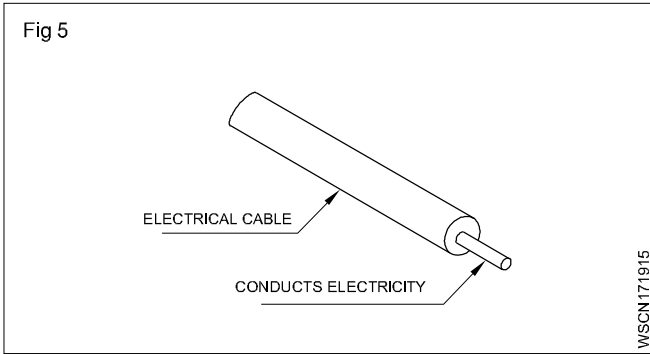

Fusibility (Fig 6)

It is the property possessed by a metal by virtue of which it melts when heat is applied. Many materials are subject to transformation in the shape (i.e) from solid to liquid at different temperatures. Lead has a low melting temperature while steel melts at a high temperature.

Tin melts at 232°C.

Tungsten melts at 3370°C.

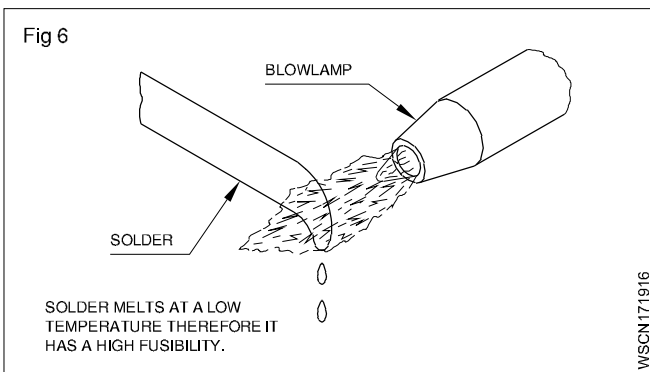

Mechanical properties

- Ductility
- Malleability
- Hardness
- Brittleness
- Toughness
- Tenacity
- Elasticity

Ductility (Fig 7)

A metal is said to be ductile when it can be drawn out into wires under tension without rupture. Wire drawing depends upon the ductility of a metal. A ductile metal must be both strong and plastic. Copper and aluminium are good examples of ductile metals.

Malleability (Figs 8 and 9)

Malleability is the property of a metal by which it can be extended in any direction by hammering, rolling etc. without causing rupture. Lead is an example of a malleable metal.

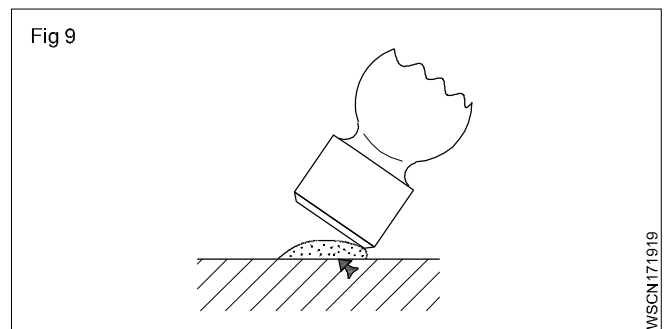
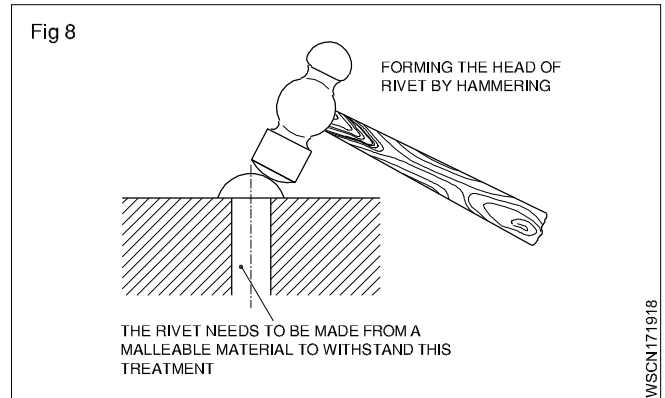
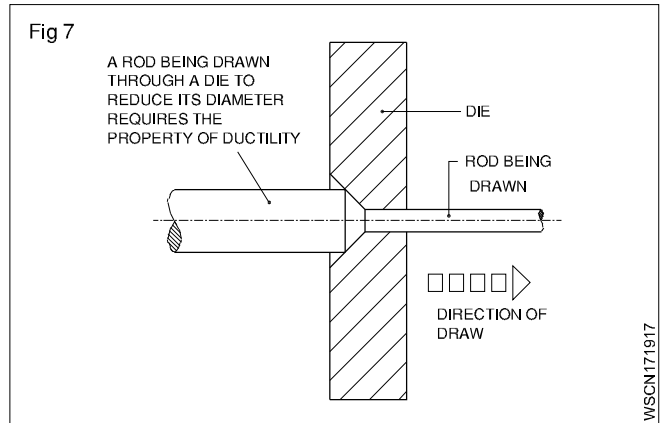

Hardness (Fig 10)

Hardness is a measure of a metal's ability to withstand scratching, wear and abrasion, indentation by harder bodies. The hardness of a metal is tested by marking by a file etc.

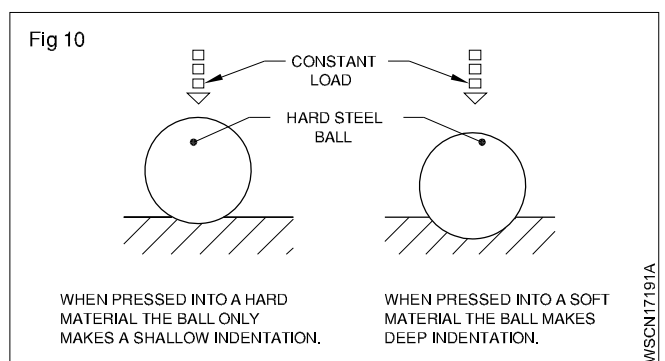

Brittleness (Fig 11)

Brittleness is that property of a metal which permits no permanent distortion before breaking. Cast iron is an example of a brittle metal which will break rather than bend under shock or impact.

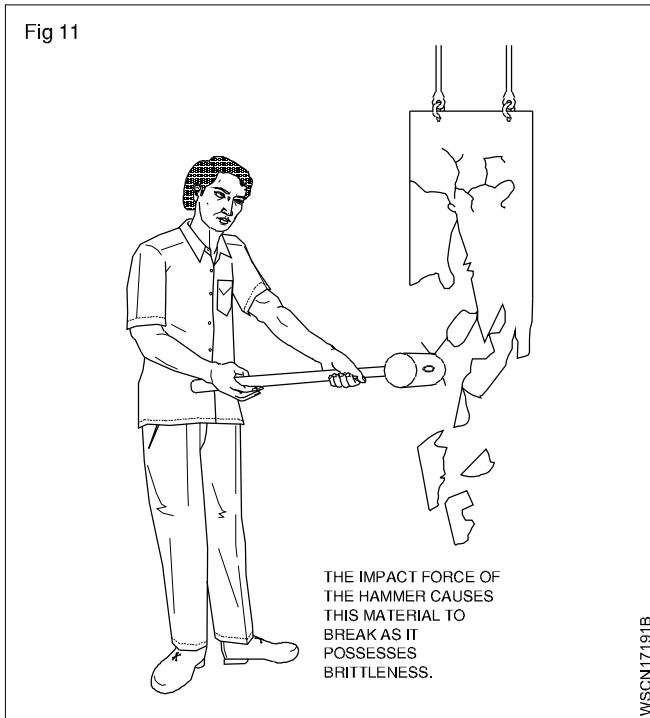

Toughness (Fig 12)

Toughness is the property of a metal to withstand shock or impact. Toughness is the property opposite to brittleness. Wrought iron is an example of a tough metal.

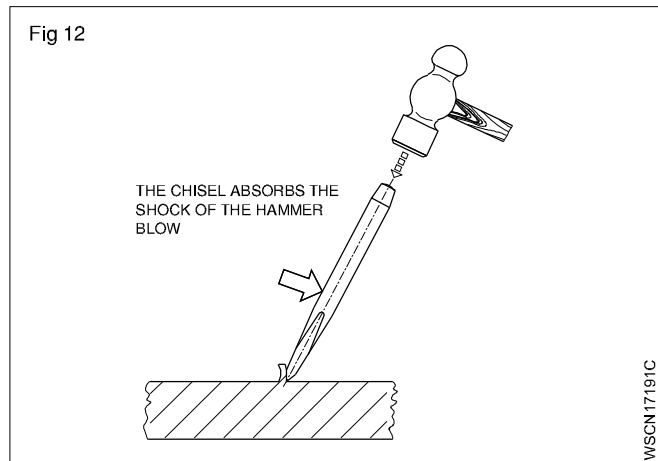

Tenacity

The tenacity of a metal is its ability to resist the effect of tensile forces without rupturing. Mild steel, Wrought Iron and copper are some examples of tenacious metals.

Elasticity

Elasticity of a metal is its power of returning to its original shape after the applied force is released. Properly heat-treated spring is a good example for elasticity.

Ferrous Metals

Metals which contain iron as a major content are called ferrous metals. Ferrous metals of different properties are used for various purposes.

Introduction of Iron, Cast Iron, wrought Iron and steel

The ferrous metals and alloys used commonly are:

- Pig-iron
- Cast Iron
- Wrought Iron
- Steels and Alloy steels

Different processes are used to produce iron and steel.

Pig-iron (Manufacturing process)

Pig-iron is obtained by the chemical reduction of iron ore. This process of reduction of the iron ore to Pig-iron is known as SMELTING.

The main raw materials required for producing Pig-iron are:

- Iron ore
- Coke
- Flux

Iron ore

The chief iron ores used are:

- magnetite
- hematite
- limonite
- carbonite.

These ores contain iron in different proportions and are naturally available.

Coke

Coke is the fuel used to give the necessary heat to carry on the reducing action. The carbon from the coke in the form of carbon monoxide combines with the iron ore to reduce it to iron.

Flux

This is the mineral substance charged into a blast furnace to lower the melting point of the ore, and it combines with the non-metallic portion of the ore to form a molten slag.

Limestone is the most commonly used flux in the blast furnace.

Properties and use of Pig-iron

Pig-iron is, therefore, refined and remelted and used to produce other varieties of iron and steel.

Cast Iron (Manufacturing process)

The pig-iron which is tapped from the blast furnace is the crude form of raw material for the cupola, and should be further refined for making castings. This refining is carried out in the cupola furnace which is a small form of a blast furnace.

Generally cupolas are not worked continuously like blast furnaces but are run only as and when required.

Cast Iron (Types)

Cast iron is an alloy of iron, carbon and silicon. The carbon content ranges from 2 to 4%.

Types of cast iron

The following are the types of cast iron.

- Grey cast iron
- White cast iron
- Malleable cast iron
- Nodular cast iron

Grey cast iron

This is widely used for the casting of machinery parts and can be machined easily.

Machine base, tables, slideways are made of cast iron because it is dimensionally stable after a period of aging.

Because of its graphite content, cast iron provides an excellent bearing and sliding surface.

The melting point is lower than that of steel and as grey cast iron possesses good fluidity, intricate casting can be made.

Grey cast iron is widely used for machine tools because of its ability to reduce vibration and minimize tool chatter.

Grey cast iron, when not alloyed, is quite brittle and has relatively low tensile strength. Due to this reason it is not used for making components subjected to high stress or impact loads.

Grey cast iron is often alloyed with nickel, chromium, vanadium or copper to make it tough.

Grey cast iron is weldable but the base metal needs preheating.

White cast iron

This is very hard and is very difficult to machine, and for this reason, it is used in components which should be abrasion-resistant.

White cast iron is produced by lowering the silicon content and by rapid cooling. When cooled in this manner, it is called chilled cast iron.

White cast iron cannot be welded.

Malleable cast iron

Malleable cast iron has increased ductility, tensile strength and toughness when compared with grey cast iron.

Malleable cast iron is produced from white cast iron by a prolonged heat-treatment process lasting for about 30 hours.

Nodular cast iron

This is very similar to malleable cast iron. But this is produced without any heat treatment. Nodular cast iron is also known as: **Nodular Iron - Ductile Iron - Spheroidal Graphite Iron**

This has good machinability, castability, resistance to wear, low melting point and hardness.

Malleable and nodular castings are used for machine parts where there is a higher tensile stress and moderate impact loading. These castings are less expensive and are an alternative to steel castings.

Wrought Iron (Manufacturing process) (Fig 1)

Wrought iron is the purest form of iron. The analysis of Wrought iron shows as much as 99.9% of iron. (Fig 1) When heated, wrought iron does not melt, but only becomes pasty and in this form it can be forged to any shape.

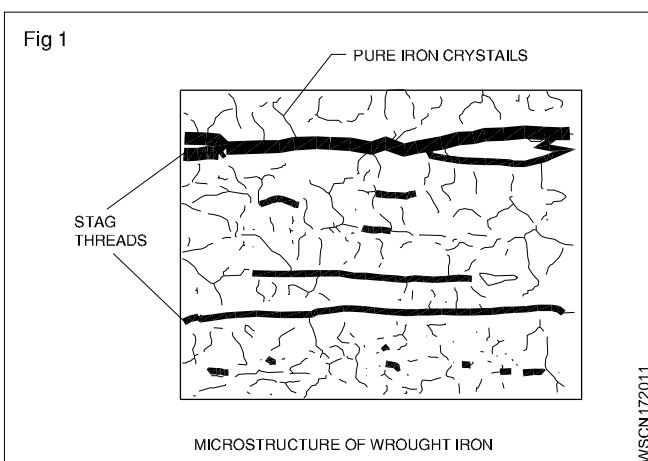

Modern methods used to produce wrought iron in large quantities are the

- puddling process
- Aston or Byers process

Steel

This is pure iron. Carbon content is more. Due to excessive carbon it is harder and tougher. Carbon content is from 0.15 to 1.5%. Besides there are other impurities like sulphur, phosphorous etc. are there which cannot be separated. This is hardened and tempered by heating it to a definite temperature and cooling it in oil or water.

The following methods are adopted for making different types of steel:

- 1 Cementation process
- 2 Crucible process
- 3 Bessemer process
- 4 Open hearth process
- 5 Electro thermo process
- 6 High frequency process.

11.13 Types of steel

Main two types of steel are:

- 1 Plain steel
- 2 Alloy steel

1 Plain steel. In this carbon and iron are mixed. According to the percentage of carbon plain steels are classified as:

- A Low carbon steel
- B Medium carbon steel
- C High carbon steel

A Low carbon steel: It is also called mild steel. In this, the percentage of carbon is from 0.15% to 0.25%. Due to less quantity of carbon is sufficiently soft and tolerates the strain. It can be put in different shapes through forging and rolling. This is not very hard or strong. This cannot be hardened or tempered by ordinary methods. Nuts, bolts, rivets, sheets, wires, T-iron and angle iron etc. are made out of it.

B Medium carbon steel: The carbon content is from 0.25% to 0.5%. Due to excess of carbon, it is harder and tougher than mild steel. The tenacity is more. This can be hardened or tempered. Various things are made by forging and rolling. This is used for making high tensile tubes, wires, agricultural implements, connecting rods, cam shafts, spanners, pulleys etc.

C High carbon steel: It has carbon content from 0.5% to 1.5%. It is very hard and wears least. This can be hardened by heat treatment. This can neither be cast nor rolled. This is very hard and tough. It acquires permanent magnetic properties. This is used for making pointed tools, springs, pumps, files, cutleries, cold chisels, press die etc.

2 Alloy Steel

When the steel is mixed with other metals like vanadium, manganese, tungsten etc., it is called an alloy steel. Alloy steel has properties of its ingredients.

Types of Alloy Steel

Two types of alloy steel are:

- A Low alloy steel
- B High alloy steel

A Low Alloy steel: Besides carbon other metals are in lesser quantity. Its tensile strength is more. The welding can work on it. This can also be hardened and tempered. It is used in manufacturing various parts of an aeroplane and cam shaft etc.

B High Alloy Steel: Besides carbon it has a high percentage of the metals higher than low steel alloy. This is classified into following types:

a High Speed Steel: It is also called high tungsten alloy steel because it has more quantity of tungsten. According to the quantity of tungsten it is classified into three types:

- 1 Tungsten 22%, Chromium 4%, Vanadium 1%
- 2 Tungsten 18%, Chromium 4%, Vanadium 1%
- 3 Tungsten 14%, Chromium 4%, Vanadium 1%

Cutting tools are made out of it because it is very hard but becomes soft at low critical temperature. This temperature is raised out of cutting process of tool, then the cutting tool becomes useless and is unfit for work. But due to high percentage of tungsten it keeps working upto high temperature. It is used for cutting tools, drills, cutters, reamers, hacksaw blades etc.

b Nickel Steel: In this 0.3% carbon and 0.25 to 0.35% nickel is present. Due to nickel its tensile strength, elastic limit and hardness is increased. It does not catch rust. Its cutting resistance increases 6 times more than plain carbon and steel due to 0.35% nickel present in it. This is used for making rivets, pipes, axle shafting, parts of buses and aeroplanes. If 5% of cobalt is mixed with 30-35% nickel, it becomes invar steel. It is mainly used for making precious instruments.

c Vanadium Steel: It contains 1.5% carbon 12.5% tungsten, 4.5% chromium, 5% vanadium and 5% cobalt. Its elastic limit, tensile strength and ductility is more. It has strength to bear sharp jerks. It is mainly used to manufacture of tools.

d Manganese Steel: It is also called special high alloy steel. It contains 1.6 to 1.9% of manganese

and 0.4 to 0.5% carbon. It is hard and less wear. It is not affected by magnet. It is used in grinders and rail points etc.

e Stainless Steel: Along with iron it contains 0.2 to 0.6% carbon, 12 to 18% chromium, 8% nickel and 2% molybdenum. It is used for making knives, scissors, utensils, parts of aeroplane, wires, pipes and gears etc.

Properties of stainless steel:

- 1 Higher corrosion resistance
- 2 Higher cryogenic toughness
- 3 Higher work hardening rate
- 4 Higher hot strength
- 5 Higher ductility
- 6 Higher strength and hardness
- 7 More attractive appearance
- 8 Lower maintenance

f Silicon Steel: It contains 14% of silicon. Its uses are multifarious according to the percentage of silicon. 0.5% to 1% silicon, 0.7 to 0.95% manganese mixture is used for construction work. 2.5 to 4% silicon content mixture is used for manufacturing electric motors, generators, laminations of transformers. In chemical industries 14% silicon content mixture is used.

g Cobalt Steel: High carbon steel contains 5 to 35% cobalt. Toughness and tenacity is high. It has magnetic property therefore used to make permanent magnets.

Material science - Difference between iron & steel, alloy steel and carbon steel

Exercise 1.3.18

Difference between iron and steel:

S.No	Basic distinction	Iron	Steel
1	Formation	Pure substance	Made up of iron and carbon
2	Types	Cast iron, Wrought iron and steel	Carbon steel and alloy steel
3	Rusting	Quickly gets oxidised and result in rust	Have different elements that protect from rusting
4	Surface	Its surface is rusty	Its surface stays shiny
5	Usage	Used in buildings, tools and automobiles	Used in buildings, cars, railways and automobiles
6	Existence	Available in nature	Has to be formed

Steel Plants in India

S.No	Name of the Steel plant	State
1	Tata Iron	Bihar
2	Indian Iron Steel	West Bengal
3	Visweshwaraiah Iron Steel	Karnataka
4	Bhilai Steel Plant	Chattisgarh
5	Durgapur Steel Plant	West Bengal
6	Alloy Steel Plant (Durgapur)	West Bengal
7	Bokaro Steel Plant	Bihar
8	Rourkela Steel Plant	Orissa
9	Salem Steel Plant	Tamilnadu
10	Vishakapatnam Steel Plant	Andhra Pradesh

Comparison of the Properties of Cast Iron, Mild Steel and steel

Property	Cast Iron	Mild Steel	Steel
Composition	Carbon contents from 2 to 4.5%	Carbon contents from 0.1 to 0.25%	Carbon contents from 0.5 to 1.7%
Strength	– High compressive strength – Poor tensile strength – Poor shearing strength	– Moderate compressive strength – Moderate tensile strength – High shearing strength	– High compressive strength – High tensile strength – High shearing strength
Malleability	Poor	High	High
Ductility	Poor	High	High
Hardness	Moderately hard and can be hardened by heating to hardening temperature and quenching	Mild	Hard
Toughness	Possesses poor toughness	Very tough	Toughness varies with carbon content
Brittleness	Brittle	Malleable	Malleable
Forgeability	Cannot be forged	Can be forged	Can be forged
Weldability	Cannot be welded with difficulty	Can be welded very easily	Can be welded
Casting	Can be easily cast	Can be cast but not easily	Can be cast
Elasticity	Poor	High	High

Ferrous metals	Non Ferrous metals
1 Iron content is more	1 Iron content is missing
2 The melting point is high	2 The melting point is low.
3 This is of brown and black colour	3 This is of different colours
4 This catches rust	4 This doesn't catch rust.
5 This can be magnetised	5 This cannot be magnetised
6 This is brittle in cold state.	6 This becomes brittle in hot state.

Difference between cast Iron and steel

Cast Iron	Steel
1 Carbon content is high	Carbon content is less
2 Carbon is in free state	Carbon is mixed
3 Melting point is low	Melting point is high
4 It cannot be magnetised	It can be magnetised
5 Because it is brittle, it cannot be forged	It can be forged
6 It rusts with difficulty	It rusts quickly
7 It cannot be welded	It can be welded

Difference between metals and non-metals

Metals	Non Metals
Shiny	dull
Usually good conductors of heat and electricity	Usually poor conductors of heat and electricity
Most are ductile	not ductile
Opaque (opposite of 'transparent')	Transparent when as a thin sheet
Most are malleable	Usually brittle when solid
Form alkaline oxides	Form acidic oxides
Sonorous (make a bell-like sound when struck)	not sonorous
Usually have 1-3 valency electrons	Usually have 4-8 valency electrons
Most corrode easily	
Usually high melting points (usually solid at room temperature except for mercury)	

Material science - Properties and uses of rubber, timber and insulating materials

Exercise 1.3.19

Properties and uses of rubber

Rubber

Rubber is an elastic material. It can be classified into

- Natural rubber
- Hard rubber
- Synthetic rubber

Natural rubber

It is obtained from the secretion of plants. It softens on heating, becomes sticky at 30°C and hardens at about 5°C.

Sulphur is added to rubber and the mixture is heated. This process is called vulcanising. By this process, stronger, harder and more rigid rubber is obtained. Further, it becomes less sensitive to changes of temperature and does not dissolve in organic solvents. Its oxidation is also minimised by increasing its weathering properties.

By adding carbon black, oil wax, etc, the deformation properties are minimised. Rubber is moisture-repellent and possesses good electrical properties. The main disadvantages of the rubber are as given under.

- Low resistance to petroleum oils.
- Cannot be exposed to sunlight.

- Cannot be used for high-voltage insulation.
- Low operating temperature (as it becomes brittle and develops cracks at a temperature of 60°C)
- Sulphur in rubber reacts with copper. Hence, copper wires are to be tinned.

Hard rubber

By increasing the sulphur content and prolonged vulcanization, a rigid rubber product called hard rubber or ebonite is obtained. It possesses good electrical and mechanical properties.

Uses

It is used for battery containers, panel boards, bushing, ebonite tubes, etc.

Synthetic rubber

This is similar to natural rubber and is obtained from thermoplastic vinyl high polymers. Some of the important synthetic rubbers are:

- Nitrite butadiene rubber
- Butyl rubber
- Hypalon rubber
- Neoprene rubber
- Silicon rubber

Sl.No.	Name	Properties	Uses
1	Nitrite butadiene rubber	Good resilience, wear resistance, flexibility at low temperature, resistance to ageing, oxidation, low tensile strength, high thermal conductivity, low hygroscopicity	Automobile tyre inner tubes.
2	Butyl	It is attacked by petroleum oils, gases and alcoholic solvents. It has thermal and oxidation stability and high resistance to ozone.	Used as insulation in hot and wet conditions, used as tapes in repair work.
3	Hypalon rubber	Resistance to deterioration when exposed to sunlight and temperature (up to 150°C).	Used in jacketing of electric wires and cables
4	Neoprene rubber	Better resistance to ageing, oxidation and gas diffusion, better thermal conductivity and flame resistance, poor mechanical properties.	Used for wire insulation and cable sheathing.
5	Silicon	High operating temperature (200°C) flexibility, moisture and corrosion resistance, resistance to oxidation, ozone, arcing, good insulating properties and thermal conductivity. It is a good insulator.	Insulation for power cables and control wires of blast furnace coke ovens, steel mills and nuclear power stations high frequency generators, boiler, airport lighting cranes.

Properties and uses of timber

General properties

Timber should have the following properties

- Straight fibres.
- Silky lustre when planed.
- Uniform colour.
- Regular annual rings.
- Heaviness.
- Firm adhesion of fiber and compact modular rays.
- Sweet smell.
- It should be free from loose or dead knots and shakes.
- The surface should not clog the teeth of the saw on cutting but should remain bright.

Classification

- Timbers are classified as
 - a Softwood
 - b hardwood

Softwood timber

- Usually all trees with needle leaves of softwood and those with broad leaves are of hard-wood.
- The wood contains resins and turpentine.
- The wood has a fragrant smell.
- Fibres are straight.
- Texture is soft and regular.
- Tough for resisting tensile stresses.
- Weak across the fibres.
- Annual rings are distinct, having one side soft, porous and light coloured. The other side is dense and dark.
- The general colour of the wood is pale tinted or light such as pine spruce, fir, ash, kail, deodar etc.

Properties of hardwood

- The wood generally contains a large percentage of acid.
- It is brightly coloured.
- Annual rings are not distinct.
- It is difficult and hard to work with.
- It resists shearing stress.
- Fibre are overlapped.
- The general colour is dark brown such as oak, walnut, teak, mahogany, sishim, babul, sal etc.

Uses

Soft timber

- Because of its cheapness it is used for low grade furniture, doors and windows for cheap type of houses.
- Used as fuel.
- Some timbers are used for baskets and mat making.
- The bark is used as garment in some places.

Hard timber

- Used for high quality furniture such as chairs, tables, sofas, dewans, beds, etc.
- Used for door, window frames for high quality houses as they can take good polish and painting finish.
- Used for manufacturing katha.

Wood as an electrical insulator

Wood is impregnated with oil or other substance, for use as insulator.

Example

It is used in electrical machine windings, as slot wedges.

Insulating materials

Description

These are the materials which offer very high resistance to the flow of current and make current flow very negligible or nil. These materials have very high resistance - usually of many megohms (1 Megohm = 10^6 ohms) are centimetre cubed. The insulators should also possess high dielectric strength. This means that the insulating material should not break down or puncture even on application of a high voltage (or high electrical pressure) to a given thickness.

Properties of insulators

The main requirements of a good insulating material are:

- High specific resistance (many megohms/cm cube) to reduce the leakage currents to a negligible value.
- Good dielectric strength i.e. high value of breakdown voltage (expressed in kilovolts per mm).
- Good mechanical strength, in tension or compression (It must resist the stresses set up during erection and under working conditions.)
- Little deterioration with rise in temperature (The insulating properties should not change much with the rise in temperature i.e. when electrical machines are loaded.)
- Non-absorption of moisture, when exposed to damp atmospheric condition. (The insulating properties, specially specific resistance and dielectric strength decrease considerably with the absorption of even a slight amount of moisture.)

Products and insulators

Insulators	Uses in electric field
1 Mica	In elements or winding (Slot insulation)
2 Rubber	Insulation in wires
3 Dry cotton	Winding
4 Varnish	Winding
5 Asbestos	In the bottom of irons and kettles, etc.
6 Gutta parcha	Submarine cables
7 Porcelain	Overhead lines insulators
8 Glass	-do-
9 Wood dry	Cross arms in overhead lines
10 Plastic	Wires insulation or switches body
11 Ebonite	Bobbin of transformer
12 Fibre	Bobbin making and winding insulation
13 Empire cloth	Winding insulation
14 Leathroid paper	-do-
15 Millimax paper	-do-
16 P.V.C.	Wire insulation
17 Bakelite	Switch etc. making, for insulation
18 Shellac	-do-
19 Slate	Making panel board
20 Paraffin Wax	Sealing